

- Dimensions (L x W x D):
- L3L4 = 248 x 50 x 30mm,
- L5 = 265 x 76 x 38mm,
- LZ180 = 166 x 38 x 38mm,
- Z3Z4Z5 = 175 x 50 x 50,5mm.
- ESL400 = 232 x 48 x 32mm,
- ESL500 = 228 x 62 x 44mm,
- ESZ = 185 x 52 x 100mm.



WEEE



CE Certification



Commercial



Industrial



Public Buildings



Multi-tenant occupancy



Residential

### Installation with one «L» for outward opening doors

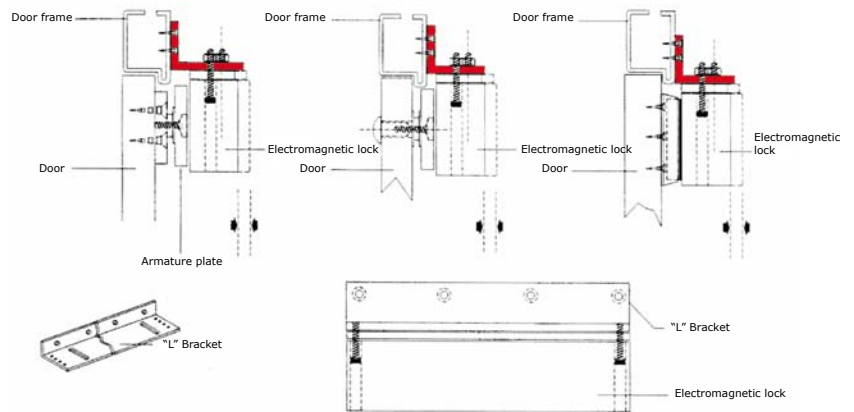

### Installation with one «L» and one «Z» for inward opening doors

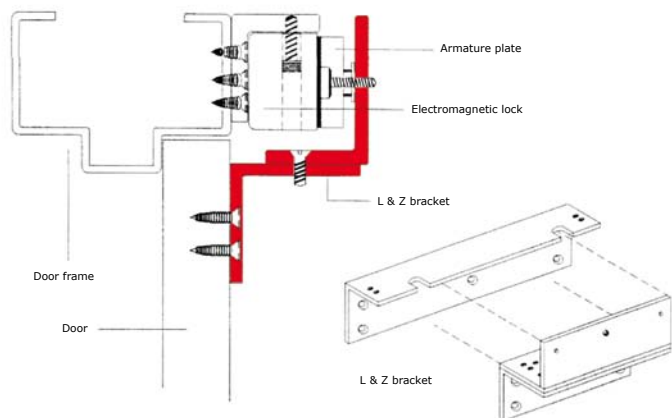

CODE	REFERENCE	DESCRIPTION
F051600003	L3L4	L-BRACKET FOR 300KG AND 400KG ELECTROMAGNETIC LOCKS
F051600004	L5	L-BRACKET FOR 500KG ELECTROMAGNETIC LOCKS
F0516000020	L3L4NFS	L-BRACKET FOR 300KG AND 400KG ELECTROMAGNETIC LOCKS - NF S 61-937
F0516000021	L5NFS	L-BRACKET FOR 500KG ELECTROMAGNETIC LOCKS - NF S 61-937
F0516000001	LZ180	Z + L BRACKET FOR 180-KG ELECTROMAGNETIC LOCKS
F0516000002	Z3Z4Z5	Z-BRACKET FOR 300KG, 400KG AND 500KG ELECTROMAGNETIC LOCKS
F0516000027	ESL400	EPOXY FINISH METAL L-BRACKET FOR 400KG ELECTROMAGNETIC LOCKS
F0516000028	ESL500	EPOXY FINISH METAL L-BRACKET FOR 500KG ELECTROMAGNETIC LOCKS
F0516000023	ESZ	EPOXY FINISH METAL Z-BRACKET FOR 400 & 500KG ELECTROMAGNETIC LOCKS

\* Refer to Limited Lifetime Warranty Conditions.