



CONTENTS

Introduction	1	Front Panel	6
Parts List	1	Indicators and fault descriptions	7
Specifications	1	Buttons	7
Physical Installation	2	Testing	8
Front panel labels	2	Service	8
Mounting to the wall	2	PipelQ™ Software	9
Pipe hole configuration	3	Appendix A -	
Exhaust pipe	4	PipelQ™ Pipe System Design	10
Wiring Installation	4	Appendix B -	
Terminal designations	5	Practical Pipe Designs	11
Relays	5		
Setting the Addresses	6		
Powering up	6		
External reset	6		



INTRODUCTION

The LT-200 FL20 Series is part of the Fire Alarm Aspiration Sensing Technology® (FAAST) family. FAAST is an advanced fire detection system for use where early warning and very early warning are a requirement. The system continuously draws air from the controlled environment through a series of sampling holes to monitor the environment for smoke particulate.

The FL20 is the addressable version of the FAAST LT-200 range, communicating with the CIE (Fire Panel) via a proprietary loop protocol. It is available in 3 different models:

FL2011EI-HS - Has single channel capability with one high sensitivity smoke sensor.

FL2012EI-HS - Has single channel capability with two high sensitivity smoke sensors in a common chamber for coincidence detection.

FL2022EI-HS - Has two channel capability with two high sensitivity smoke sensors in separate chambers. (One sensor for each channel).

This guide provides information for mounting the unit, basic installation and advice on pipe layout designs, together with an overview of using the PipelQ software (version 2.9.1 or higher) to achieve EN54 compliant designs. For more complex designs using increased functionality (experienced users only) please see the FAAST LT-200 Advanced Setup and Control Guide - reference D200-100-01.

Important Note

Aspirating Smoke Detectors supplied and installed within the EU must conform to the EU Construction Products Regulation (CPR) 305/2011 and the related European Product Standard EN 54-20. FAAST LT-200 has been tested and certified to ensure that it conforms to the necessary Standards, but strict adherence to this instruction guide is advised to ensure that the installation meets the requirements of the CPR.

The PipelQ software (use version 2.9.1 or higher) is a design application to help a user create or verify EN54 compliant pipe layouts, and to allow configuration of the FAAST LT-200 unit.

Warning

The performance of this system is dependent upon the pipe network. Any extension or modification to the designed installation may cause improper operation. The operational effects of such changes need to be verified using the PipelQ design software.

This equipment and all associated pipe work must be installed in accordance with all relevant codes and regulations.

PARTS LIST

Description	Quantity
FAAST LT-200 unit	1
Mounting bracket	1
3-pin Terminal block	6
4-pin Terminal block	1
2-pin Terminal block	3
47 k-ohm EOL Resistor	2
USB Cable	1
Front Panel Labelling Pack	1
Wiring Diagram Label	1
Installation Kit USB Pen Drive	1
Quick Installation Guide	1

SPECIFICATIONS

Electrical Characteristics

Voltage Range:	18.5 - 31.5 VDC
Supply Current: 1 Channel:	170mA (typical); 360mA (max) @ 24 VDC 25°C (excluding sounders)
2 Channel:	270mA (typical); 570mA (max) @ 24 VDC 25°C (excluding sounders)
Com. Loop Supply Voltage:	15 – 29 VDC (Loop current ≤ 900mA)
Com. Loop Standby Current:	@ 24V: 900 µA max. (2 sensors + 2 channels polled once every 5s)

Module Isolator Characteristics

Maximum rated switching current (under short circuit, Is max):	0.9A @ ≤ 29V
Maximum leakage current (IL max) with the switch open (isolated state):	15mA
Maximum series impedance with the switch closed (Zc max):	190 m ohm at 15Vdc; 1A
Power Reset:	0.5s
Configurable Input:	Activation Time: 2s (min)
Relay Contact Ratings:	2.0 A @ 30 VDC, 0.5A @ 30 VAC

Environmental Ratings

Temperature:	-10°C to 55°C
Relative Humidity:	10% to 93% (non-condensing)
Flow Fault:	± 20% of the reference flow
IP Rating:	65

Mechanical

Exterior Dimensions: See Figure 1
 Wiring: 0.5 mm² to 2 mm² max
 Maximum **Single** Pipe Length: 100m (Class C)
 Maximum **Branched** Pipe Length: 160m (2 x 80m, Class C)
 Maximum Number of Holes: See Table 1A
 Pipe Spec (EN54-20 Compliance): to EN 61386
 (Crush 1, Impact 1, Temp 31)
 Outside Pipe Diameter: 25mm (nom) or 27mm (nom)
 Shipping Weight: 6.5kg (inc sensors)

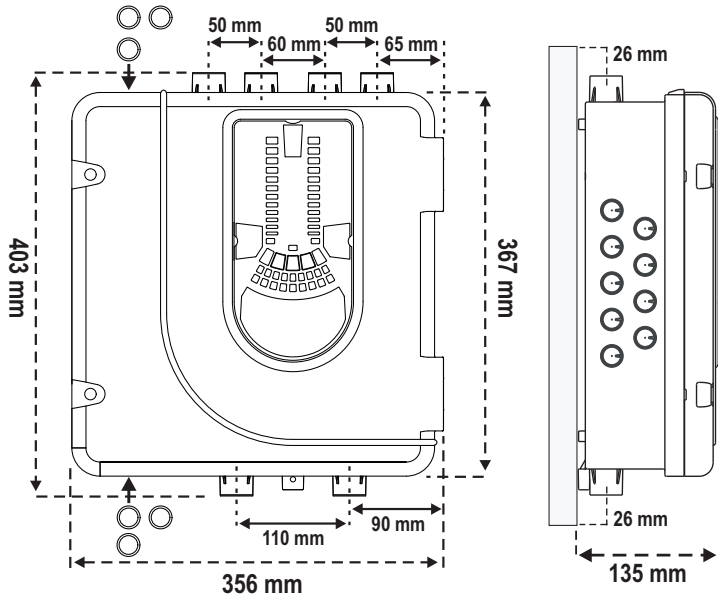

Figure 1: Dimensions and Knock-Outs

PHYSICAL INSTALLATION

Front Panel Labels

The LT-200 FL01 is shipped without the front panel labels fixed in place. This allows the installer to choose the language required for the installation from the Front Panel Labelling Pack.

Figure 2 shows where the labels need to be placed:

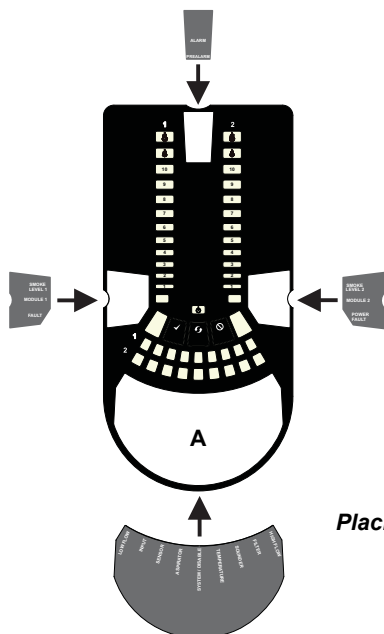

Figure 2: Placing the Front Panel Labels

When label **A** is in place, remove the protector from the bottom of the clear cover to stick the cover down, as shown in Figure 3:



Figure 3: Remove Backing to Stick Cover Down

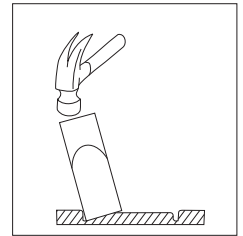

Figure 4: How to Knock Out Cable Gland Holes

Cable Access

Knock out cable gland holes where required. The location of the cable gland holes is shown in Figure 1, represented by the icon:



Mounting the LT-200 FL20 to the Wall

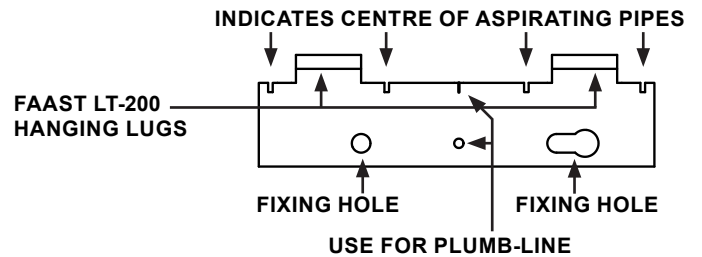
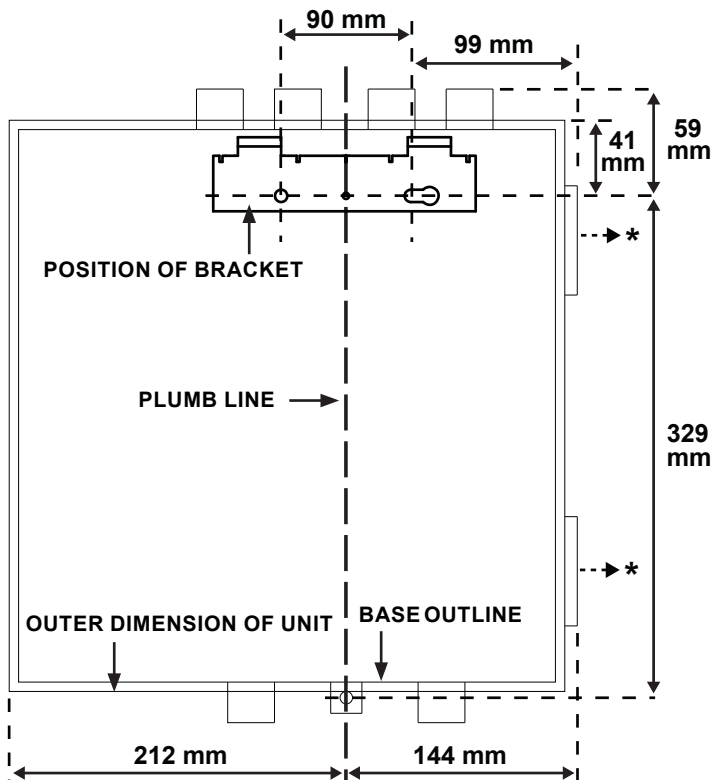

Figure 5: Mounting Bracket



* Minimum clearance required from hinges to open door = 35 mm.

Figure 6: Fasten the mounting bracket to the wall

Figure 7: Sequence (1 to 9) to Mount the Detector on the Bracket

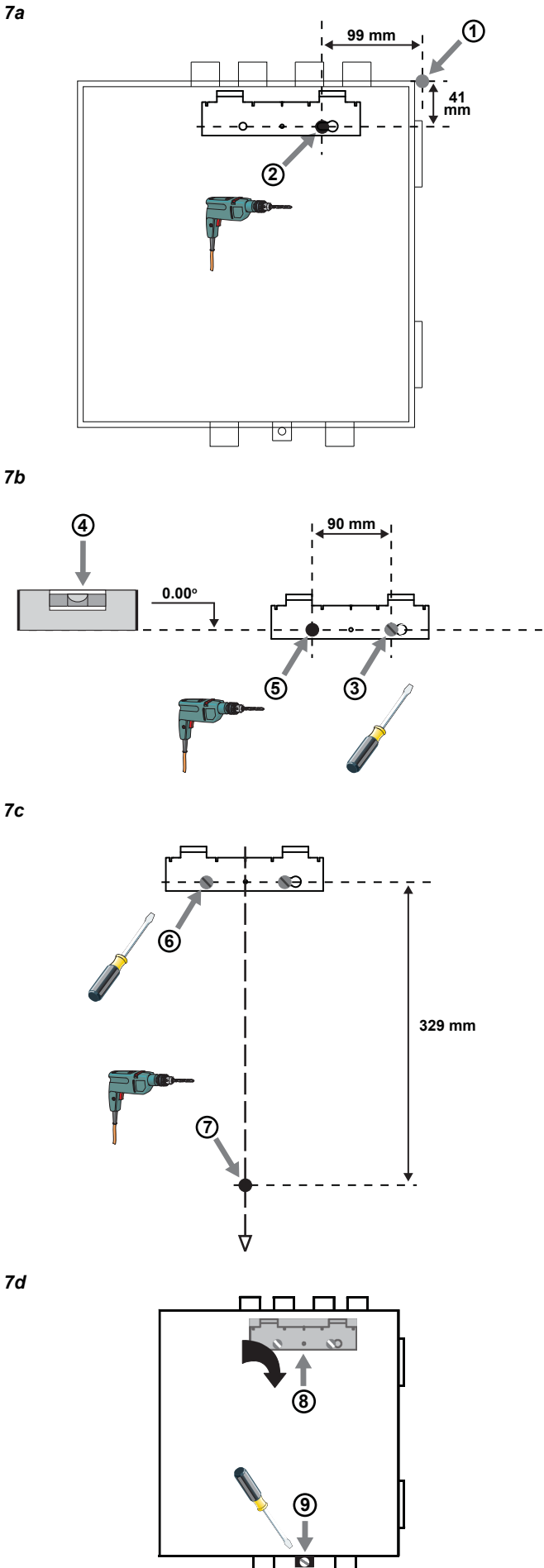

Pipe Hole Configuration

Figure 8 below shows the pipe holes available on the unit. Each unit has 2 pipe holes per channel connected together like a T-Piece. If using a 1 channel unit, holes 3 and 4 do not function. Use **Table 1** to locate the holes required for the installation:

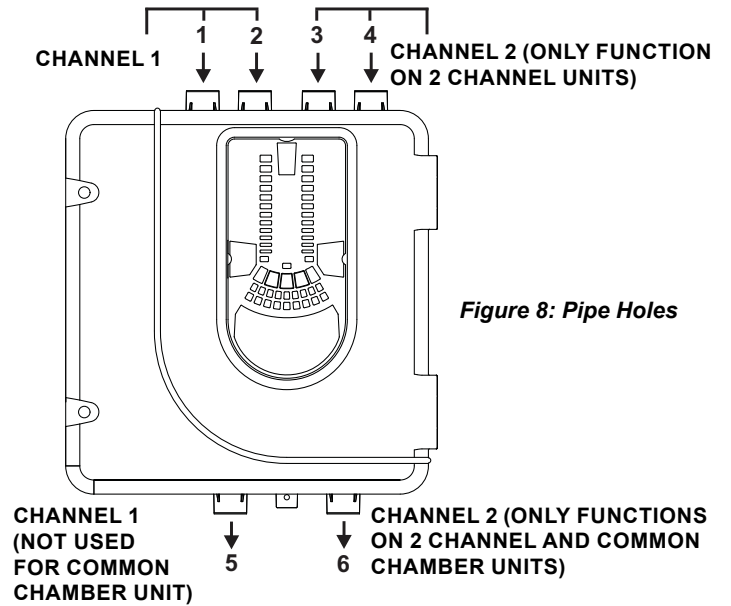

Figure 8: Pipe Holes

Table 1: Pipe Holes Used for Each FAAST LT-200 Model

FAAST LT MODEL	INLET PIPE HOLE	OUTLET PIPE HOLE
FL2011EI-HS	1 and / or 2	5
FL2012EI-HS	1 and / or 2	6
FL2022EI-HS	Channel 1 - 1 and / or 2 Channel 2 – 3 and / or 4	5 6

Note 1: Pipe holes not used should be kept sealed.

Note 2: Do **NOT** glue pipes into the pipe holes.

Table 1a: Maximum Number of Pipe Holes Allowed Per Channel

All figures quoted using highest (level 1) sensitivity

CLASS	PIPE LENGTH (m)	MAX No HOLES /CH	HOLE SIZES
C	100	18	6 x 2mm + 6 x 2.5mm + 6 x 3mm (+ 3.5mm non sensing end hole)
C	160 (2 x 80) Using T-Piece	18 (9 x 2)	2 x [3 x 2.5mm + 6 x 3mm] (+ 3mm non sensing end hole)
B	80	6	6 x 4mm (inc 4mm sensing end hole)
A	80	3	1 x 5mm + 1 x 6mm (+ 6.5mm sensing end hole)

Pipe Installation

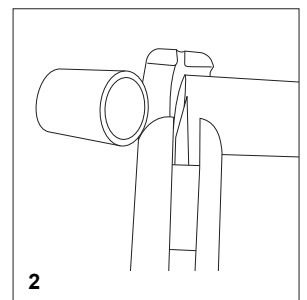
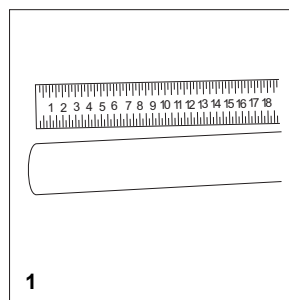

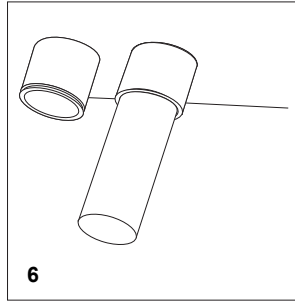
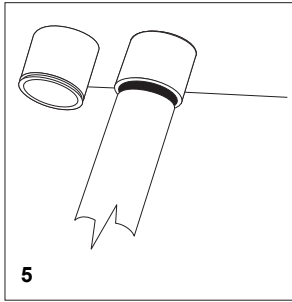
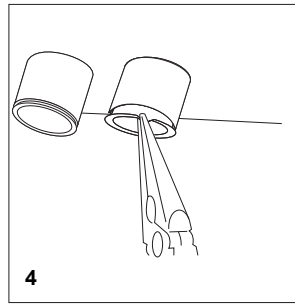
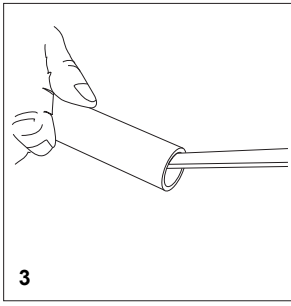

IMPORTANT NOTES

- 1) Do not glue the pipes into the inlets or outlets of the FAAST LT-200 unit. **Devices with glued pipes will be deemed as out of warranty because they cannot be tested.**
- 2) It is recommended that the inlet and outlet connections remain plugged prior to use, and the outlet is temporarily sealed if the device is turned off during maintenance periods to prevent ingress of insects and spiders.

Exhaust Pipe

Whenever the FAAST LT-200 is installed outside the risk area, return of the exhaust air back into the protected area can reduce flow faults due to pressure difference.

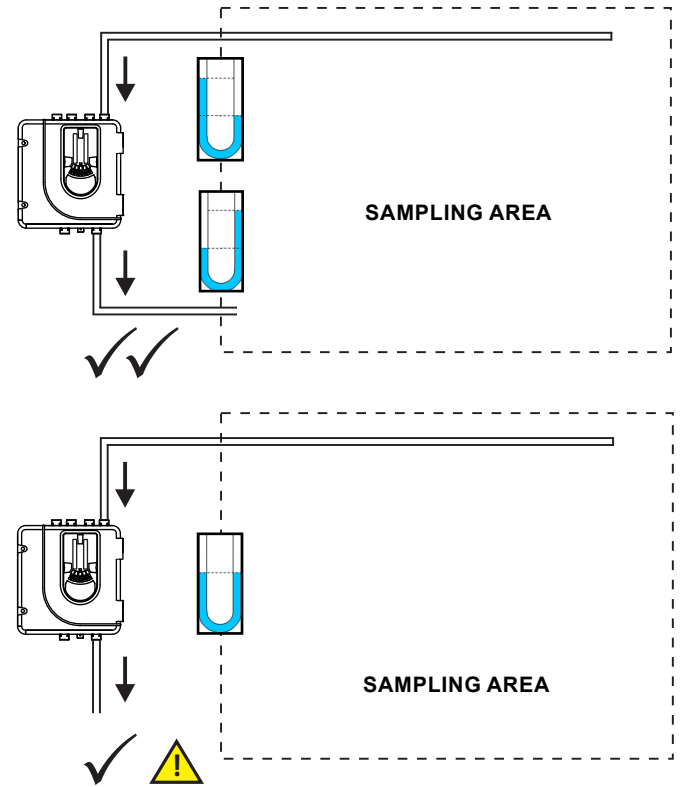

WIRING INSTALLATION

Power, Alarm and Control Connections

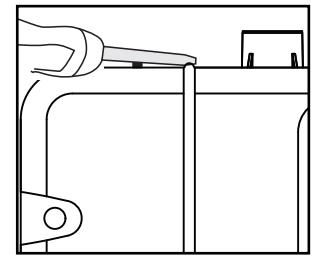
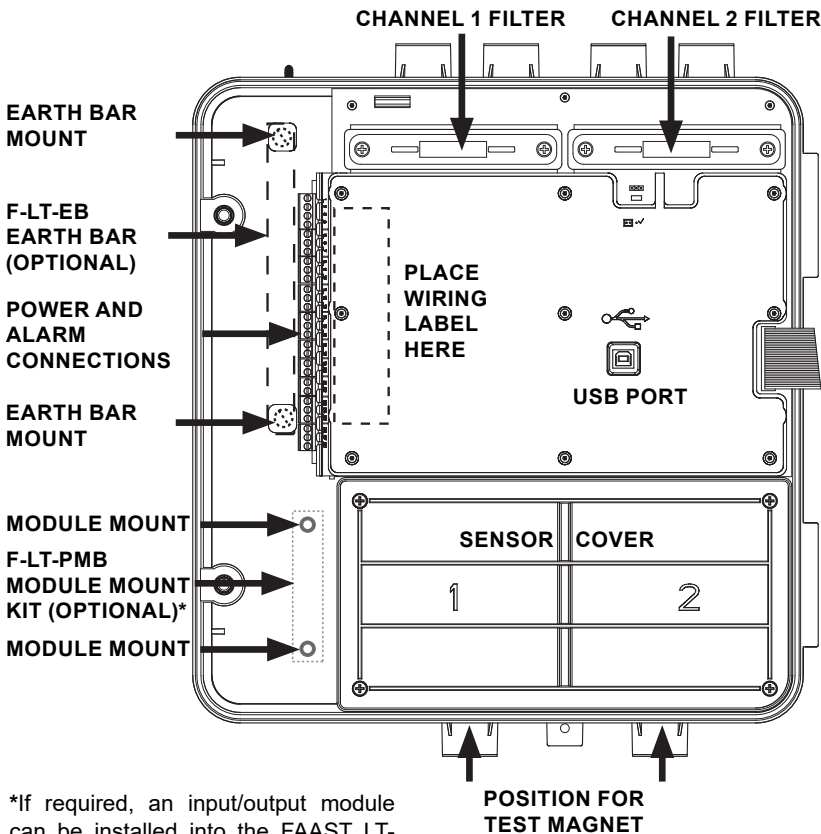

If the FAAST LT-200 door is closed for a long time (especially at high temperatures) it may be necessary to use a flat-bladed screwdriver between the two tabs at the top of the unit to lever open the door (as shown above).

Figure 9: Inside the Detector

Note 1: All wiring should comply with local requirements and regulations.

Note 2: Panel wiring must observe the recommendations of the panel manufacturer

*If required, an input/output module can be installed into the FAAST LT-200 unit. The optional module mount kit (F-LT-PMB) will be needed for this.

Fitting the Terminal Blocks

To insert the terminal blocks into the unit use the following method:

- 1 Insert a corner of the block into the slot (see a).
- 2 Push the length of the block into the slot until the block 'clicks' into place, the 2 upper hooks on the block should be visible (see c).

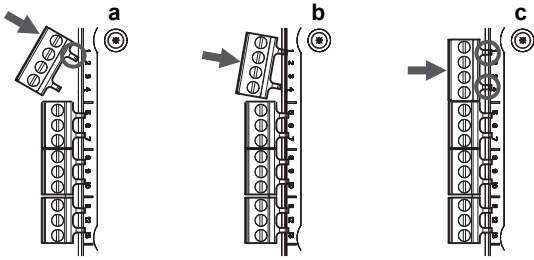

Table 2: Wiring Terminal Designations

(Note - Terminals marked CH2 will only be available on 2 channel models)

No.	Function			
1	Ext Power In +		Primary PSU	
2	Ext Power In -		Primary PSU	
3	Aux Power In +		Not used in default	T1
4	Aux Power In -		Not used in default	
5	NC Alarm Relay	CH1		T2
6	C Alarm Relay	CH1		
7	NO Alarm Relay	CH1		
8	NC Alarm Relay	CH2		T3
9	C Alarm Relay	CH2		
10	NO Alarm Relay	CH2		
11	NC Fault Relay	CH1		T4
12	C Fault Relay	CH1		
13	NO Fault Relay	CH1		
14	NC Fault Relay (AUX)	CH2		T5
15	C Fault Relay (AUX)	CH2		
16	NO Fault Relay (AUX)	CH2		
17	Sounder Output 1 -		47 k-ohm EOL Resistor	T6
18	Sounder Output 1 +			
19	Sounder Output 2 -		47 k-ohm EOL Resistor	T7
20	Sounder Output 2 +			
21	Configurable Input +	(Reset)	Default is active = short circuit	T8
22	Configurable Input -	(Reset)	(unsupervised)	
23	Not Used			T9
24	Loop out -			
25	Loop switched out +		To use isolator	
26	Loop in -			T10
27	Loop in +			
28	Loop not switched out +		Internally connected to 27	

WARNING: Switching Inductive Loads

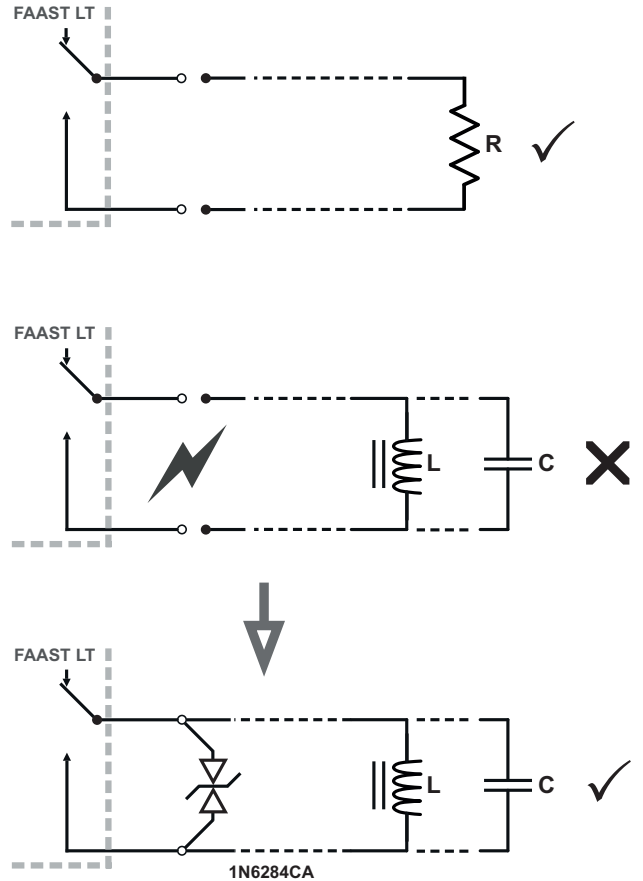

Table 3: Relays

RELAY	ACTION:	NOTES
ALARM 1 or 2	Controlled by panel when it determines alarm condition has been met.	Set ON and OFF by panel; not latched
FAULT 1 or 2	When FAULT CONDITION on Ch1 or Ch2 or a common FAULT occurs. Fault is also signalled when in Service Mode and when the device is unpowered.	Fault state is not latched.
SOUNDER 1 or 2	Set ON when a channel is in ALARM. Sounder 1 corresponds to Ch1 and Sounder 2 corresponds to Ch2	Default condition = set on in ALARM.

Table 3a: Relay Electrical Specification

SPECIFICATION	MIN	MAX	UNITS	COMMENTS
Contact Rating		2 0.5	A A	30 VDC resistive load 30 VAC resistive load
Life Time	10 ⁵		Operations	

SETTING THE ADDRESSES

Each aspiration channel uses loop communications to report its status information to the CIE (Fire Panel). As a factory default, the unit will report smoke alarm and sensor information at an associated sensor address and general alerts and faults on a different module address.

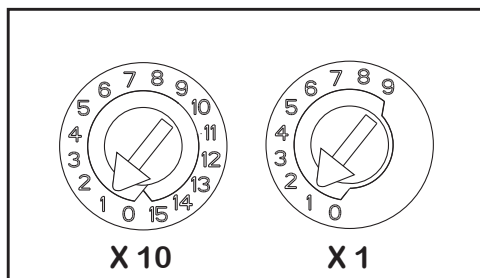

Figure 10: Address Switches

Sensor

The sensor address is set on rotary decade switches on the back of the smoke sensing devices. The smoke sensors are located under the sensor cover inside the unit (see Figure 9). The **Smoke Sensors** section of **Maintenance** - later in the manual - shows how to remove the sensors. As supplied, the default for channel 1 is Address 1; in 2 channel units (or when two sensors are fitted) the second device is set to Address 2. (Note: The number of addresses available will be dependent on panel capability, check the panel documentation for information on this).

Note: The sensors communicate with the fire panel through the loop connection whether the 24VDC power supply is on or not.

Module

The module address is set by means of rotary decade address switches located behind the door of the unit. Use a screwdriver to rotate the wheels to the desired address. The selected address refers to channel 1; on 2 channel units the device assigns the next (+1) module address to channel 2 automatically. Hence, address 159 is not valid for channel 1. (Note: for control panels that use only 99 addresses, 99 is invalid for channel 1.)

Note: The module address will only respond to a panel poll when in **Normal** mode with the 24VDC power supply on.

POWERING UP

Using Default Settings

1. Connect a suitable 24VDC supply (complying with European Standard EN 54-4) to pins 1 and 2 on terminal block T1 (See Table 2)
2. Check the voltage at the connector. Make sure it is within the required voltage range.
3. If the voltage is within the specified range, connect the power connector to the unit.
4. Close and secure the housing door; verify the fan starts up and air flows out of the exhaust port. The unit takes 1-3 minutes to initialise and stabilise in normal mode.

EXTERNAL RESET

The default setting for the configurable external input is Device Reset (terminal block T8). A momentary short circuit connection between these terminals will cause the FAAST LT-200 unit to perform a reset.

FRONT PANEL

The front panel will be different depending on which of the 3 FL01 models is being installed, and each is shown below.

The following information is displayed:

- Detector Status: Normal, Alarm, Fault or Isolate
- Alarm Level; Alarm, Pre-Alarm
- Particulate Levels; 1-9
- Flow Level
- Test, Reset and Disable Buttons

Figure 11: Front Panel Display

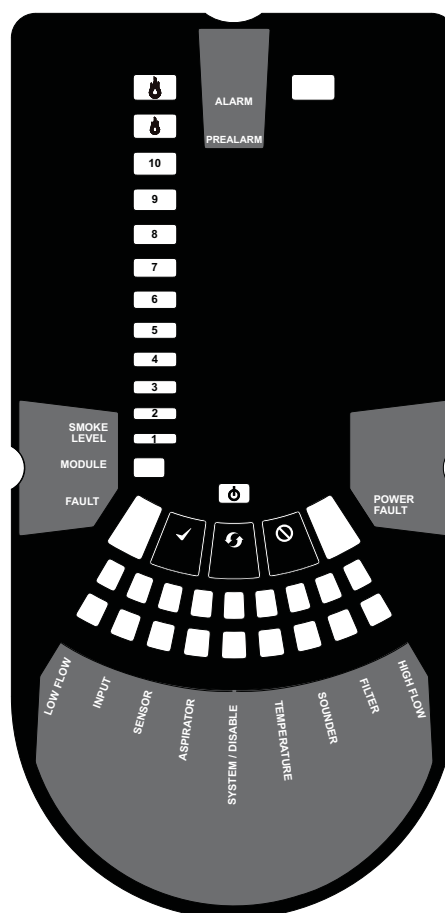

11a: FL2011EI-HS / FL2012EI-HS 1 Channel Detector

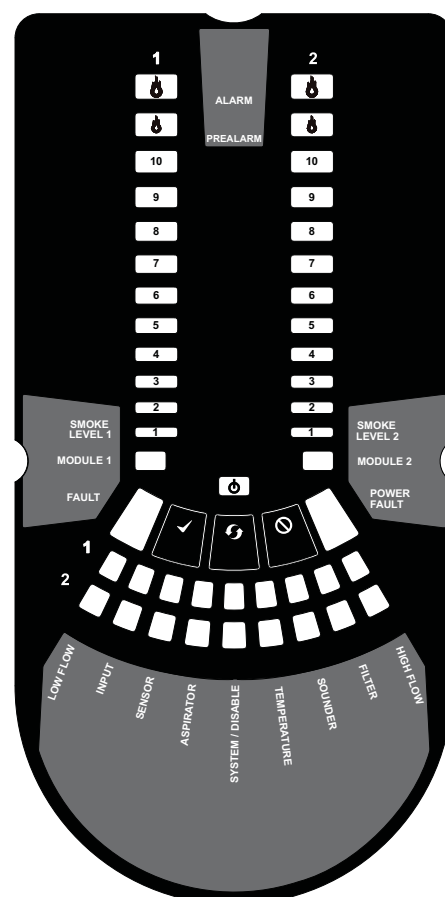

11b: FL2022EI-HS 2 Channel Detector

Table 4: Front Panel Indicators and Fault Descriptions

INDICATOR	ACTION	WARNING OR TROUBLE	COMMENT / ACTION
CHANNEL 1/2 ALARM	ON Red (Set by panel)	Channel is in alarm (relay is set ON with no delay)	Default setting
	1 BLINK Green (Polled by panel)	When sensor is polled	Not when in alarm
CHANNEL 1/2 PRE-ALARM	ON Yellow	Channel is in pre-alarm	Only with panels using Advanced Protocol
SMOKE LEVEL 1/2	ON Yellow (Set by panel)	Led number indicates sensor alarm level reached	Only numbers 1 – 9 used - only with panels using Advanced Protocol
CHANNEL 1/2 MODULE	ON Green		Controlled by panel
	BLINK Green	Module communication	Controlled by panel
FAULT	ON Yellow	Common or multiple faults	
POWER	ON Green	FAAST LT is powered	Displays Yellow when initialising
POWER FAULT	ON Yellow	Low power alert / high power fault	Check the power supply voltage.
	1 BLINK Yellow	Power on alert	Disabled as default
CHANNEL FLOW INDICATORS 1/2	ON Green	The LED indicates the air flow for a channel: - Centre = normal flow - Left = flow low; (-20% at extreme) - Right = flow high; (+20% at extreme)	On 2 channel unit: Upper row = Ch1 Lower row = Ch2
INDICATOR	ACTION	WARNING OR TROUBLE	COMMENT / ACTION
LOW FLOW	1 Blink Yellow	Fault delay in progress	Default is 60s; general fault set at end of delay
	ON Yellow	Low flow fault	Check filter; check pipe network for blockages
INPUT	1 BLINK Yellow	External input fault	Not used with default settings
SENSOR	2 BLINKS Yellow	Sensor communication fault	Check sensor addresses and installation; replace sensor.
ASPIRATOR	ON Yellow	Air flow sensor fault	Try to restart device.
	1 BLINK Yellow	Flow initialization fault	Check filter; check pipe network for blockages; try to restart device.
	2 BLINKS Yellow	Fan fault	Try to restart device.
DISABLE	1 BLINK Yellow	Alarms & alerts not reported	Returns to Maintenance then Normal operation after 60min (default)
SYSTEM	1 BLINK Yellow	Wrong configuration	Flashes all FAULT LEDs; try to restart device.
	2 BLINKS Yellow	EEPROM fault	Check power supply voltage. Try to restart device
	3 BLINKS Yellow	Real time clock fault	RTC is corrupted or time reading failed.
TEMPERATURE	1 BLINK Yellow	Low temperature alert	Check the air flow temperature
	2 BLINKS Yellow	High temperature alert	Check the air flow temperature
SOUNDER	1 BLINK Yellow	Sounder fault	Check the sounder circuit and the EOL
FILTER	1 BLINK Yellow	Filter alert at set date	No date set as default
HIGH FLOW	1 Blink Yellow	Fault delay in progress	Default is 60s; general fault set at end of delay
	ON Yellow	High flow fault	Check pipe network for breaks or leaks.

In case of simultaneous alerts/faults on the same LED, priority order is: ON (Highest), 1 blink, 2 blinks, 3 blinks (Lowest)

Note: The channel alarm and smoke level LEDs are under the control of the CIE (Fire Panel).

Front Panel Buttons

The front panel has 3 user buttons: **TEST**, **RESET** and **DISABLE**. These buttons are used to enter the pass-code which then allows the user to carry out simple test functions.

Note: In *Remote Maintenance and Service Mode*, these buttons are always disabled.

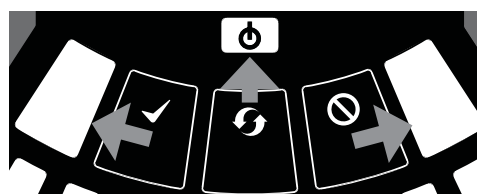







Figure 12: User Interface Buttons

Table 5: Front Panel Buttons

BUTTON	NORMAL Mode	MAINTENANCE Mode
 RESET	When pressed for 2 s, starts PASSWORD PROCEDURE to enter Maintenance mode.	When pressed for 2 s latched alarms, faults and sounders (relays) are reset. Alarm controlled by panel. If alarm persists, set again immediately after the reset In DISABLE Mode, if pressed for 2 s unit will exit from DISABLE Mode (but remains in MAINTENANCE Mode)
 DISABLE	Used to increment Password digits in PASSWORD PROCEDURE	When pressed for 2 s, device enters DISABLE Mode for 60 minutes (default). Alarm and fault relays reset. Smoke sensors continue to report alarm and their faults to the panel. (To exit DISABLE Mode see RESET)
 TEST	Used to confirm password in PASSWORD PROCEDURE. Default Password = 3111	When pressed for 2 s and released, both sensor will simulate alarm When pressed for 4 s and released, sensor #1 will simulate alarm When pressed for 6 s and released, sensor #2 will simulate alarm Warning: Outputs will be activated by test
COMBINATIONS		
 RESET + DISABLE	When pressed for 2 s, shows fan speed (on smoke level scales) for a preset time.	When pressed for 2 s, shows fan speed (on smoke level scales) for preset time.
 RESET + TEST	No action	When pressed for 2 s, turns off sounders
 RESET + TEST + DISABLE	No action	When pressed for 2 s, unit exits from MAINTENANCE Mode

Password Sequence to Enter *Maintenance Mode*



- 1) Press and hold **RESET**; Left flow indicator will turn yellow, then green.
- 2) Release **RESET** and **FAULT** indicator will switch on green. The left flow indicator will blink green indicating the device is ready for the first digit.



- 3) Press **DISABLE** to increment the LEDs 1...9.



- 4) Press **TEST** to select a digit.
- 5) The flashing airflow segment will turn solid green and the next segment will begin to flash indicating set the next digit.
- 6) When the 4th digit is selected, all 4 airflow segments are turned off. If the password is accepted the **FAULT** indicator will remain green and the unit enters **Maintenance** mode. If the password is incorrect the **FAULT** indicator flashes yellow and the unit remains in **Normal** mode.

The **Default Password** is **3111**.

If no button is pressed for 10s during the password sequence, the unit returns to **Normal** mode.

Exit from *Maintenance Mode*

press the three front panel user interface buttons **TEST**, **RESET** and **DISABLE** simultaneously for 2 seconds.

Alternatively, reset the unit using the **Remote Input** (when set to default value) or power the device off and on again.

If there is no activity in **Maintenance** mode for 5 minutes (default), the **FAULT** indicator blinks green for 15s and then the unit automatically returns to the **Normal** state.

TESTING

Note that the sensor LEDs, which are under the control of the CIE (Fire Panel), must be turned on to activate the front panel alarm indicators.

Magnet Test

The alarm signalling can be tested for functionality by placing a test magnet in the position shown in Figure 9 (displayed earlier in the guide). This method does not reflect EN54 standards and does not test the air flow in the pipe-work.

Smoke Testing

The system alarm response can be tested for functionality using smoke. The choice of smoke source is dependant on the installation but in all cases the smoke must be present for the duration of the test. Smoke pellets or matches can be used close to the sampling point to introduce smoke particulates into the system. It is recommended that smoke with a particulate life cycle of greater than 120s should be used – *standard aerosol sprays for point detector testing do not work well on aspirated systems.*

Fault Testing

Simulate a fault on the detector (for example, block the outlet pipe) and check that a fault is signalled on both the front panel of the unit and at the CIE (Fire Panel).

SERVICE

WARNING

Isolate the aspirating detector from the fire alarm system to prevent any unwanted alarms when opening the front door of the unit. Make sure all power is removed from the system before removing any covers.

Service Mode

Opening the cabinet door during normal operation will cause the unit to enter **Service** Mode. The **FILTER** LEDs will blink, the unit will switch off power to the fans and stop communicating with the fire panel (the

smoke sensors continue to communicate with the panel). When the cabinet door is closed, the unit restarts automatically.

Filters

Periodic cleaning or replacement of the filters will be required.

The filters are located inside the cabinet at the top of the unit (see Figure 9 displayed earlier in the guide) and are removed as shown in the sequence below:

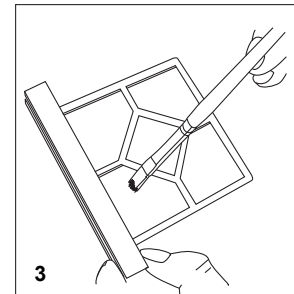
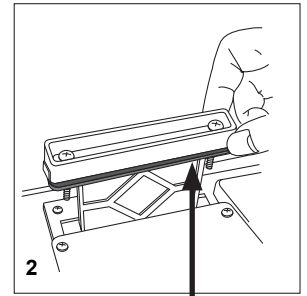
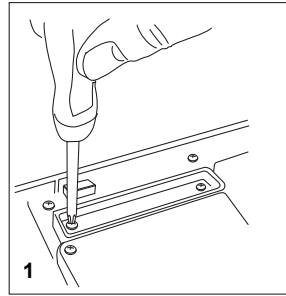

FOAM GASKET

Either replace the filter assembly or carefully brush off the accumulated dust. (Replacement filter part number: FL-IF-6.)

Note: If replacing the filter, remove the foam gasket from the old filter and place onto the new filter. When placing the new filter into the slot, ensure that the gasket is correctly aligned.

Refit the filter, close and secure the cabinet door. The unit will initialise and restart.

Smoke Sensors

The smoke sensors are located under the sensor cover (see Figure 9 displayed earlier in the guide). To access the sensors, follow the sequence below:

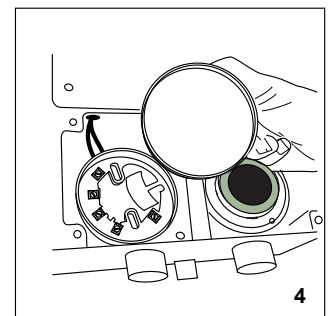
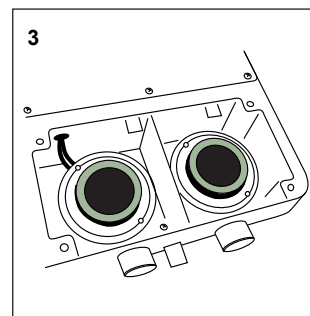
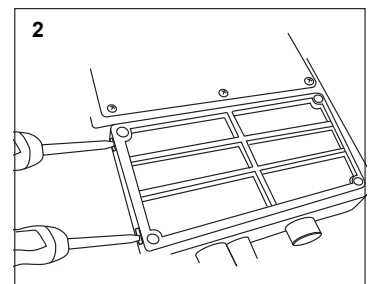
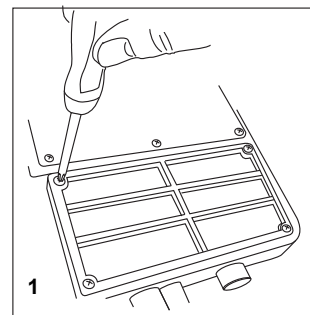

Turn the sensor head anti-clockwise to remove from base (and clockwise to relocate). Do **NOT** interchange the devices and do **NOT** alter the rotary address switch settings on the sensors. If replacing a sensor, ensure that the address set on the new sensor is the same as on the sensor being replaced. Use **ONLY** model number F-SEN-SSE as a replacement sensor.

WARNING

Using compressed air to clean the pipe system

High pressure air flushed through the system could damage the fan, ensure that the FAAST LT-200 unit is sealed or detached from the system before commencing this procedure.

USB Connection

PC connectivity is provided by an on board USB **B** port located centrally between the filter and the sensor cover (see Figure 9 displayed earlier in the guide). The USB interface allows access to the PipelQ application software running on a PC.

Note: The USB connecting cable should be removed during normal operation.

Changing Default Settings / Verifying a Pipe Layout Design

To change any of the default options, or to use the pipe layout design function, it will be necessary to connect the detector to a PC/laptop with the PipelQ software installed (version 2.9.1 or higher). For more complex designs using increased functionality (experienced users only) see the *FAAST LT-200 Advanced Setup and Control Guide* for further information.

PipelQ™ SOFTWARE

The PipelQ software is supplied on a USB pen stick with the device, or can be downloaded from www.faastr-detection.com. **For the FAAST LT-200, it is necessary to use PipelQ version 2.9.1 or higher.**

Note 1: It is strongly recommended that some form of training is taken before using any version of PipelQ (contact your distributor for information on this). The information provided here is only a brief introduction.

Note 2: To connect a FAAST LT-200 to a PC using the USB port, the PipelQ software must be running on the PC and the device must be in **Maintenance** mode (See *Password Sequence to Enter Maintenance Mode* section previously).

Connecting a PC to a FAAST LT-200 Device for the First Time

Minimum System Requirements

Microsoft Windows Vista, 7, 8 or 10, XP - SP3 (not recommended).

1 GB of RAM.

Graphics hardware with 128 MB of memory and support for OpenGL 2.0 or later.

5 GB of free hard disc space

When the PipelQ installation is complete:

- 1) With PipelQ open on the PC and the device in *Maintenance* mode, open the device front door by releasing the two Phillips screws.
- 2) Connect a USB cable from the internal port in the centre of the device to a spare USB port on the PC (make sure that the USB connector is pushed fully into the FAAST LT-200 port until it clicks). The device will now be in **Remote Maintenance** mode.

The USB connection must be made within 5 minutes of entering the *Maintenance* mode password.

The first time a PC running PipelQ is connected to a FAAST LT-200 device, the USB port drivers will be installed.

- 3) In PipelQ, open the project file (.mdf file) that is associated with the FAAST LT-200 device being used. If no project file has been created yet, click on **New** and create a new project. Accept the PipelQ disclaimer, select the measurement units, device type and number of channels. **Make sure that the device type selected matches the type of FAAST LT-200 device being used.** The project will assume the factory default configuration for a device.

- 4) In the Left Hand pane of PipelQ, left click on the FAAST LT-200 device in the system tree to highlight it. Right click on the FAAST LT-200 icon in the left hand pane to reveal the menu. Click on **Connect Device**.

Note that to use the full range of connection options, a user must be connected to the FAAST LT-200 device as an **Administrator**. Tick the **Admin** box and enter the *Administrator* password to access these extra commands. The *Administrator* password is the same as the *Remote Maintenance* password (the default is 3111).

- 5) Click on **Connect**. The detector is connected when a small green tick is indicated on the device icon. *FAAST LT-200 Connected* is shown at the bottom left corner of the screen.
- 6) Depending on what operations are required, select the *Configuration*, *Design* or *Monitoring* tab at the bottom of the screen as necessary.

For greater detail on using PipelQ with the FAAST LT-200 see the *FAAST LT-200 Setup and Troubleshooting Guide*. For information on using the *Configuration*, *Design* and *Monitoring* tabs in PipelQ, see the *FAAST LT-200 Advanced Setup and Control Guide*.

Setting the Fan Speed

A default air velocity reference value is set into each FAAST LT-200 unit before leaving the factory. This equates to an optimum air flow of approximately 45 l/min. Default high/low flow limit thresholds are set to guarantee a flow fault when the air flow is $\pm 20\%$ of the reference flow. The FAAST LT-200 fan speed in each channel can be set to *Auto* or *Manual* control. Use *Auto* mode in normal operation.

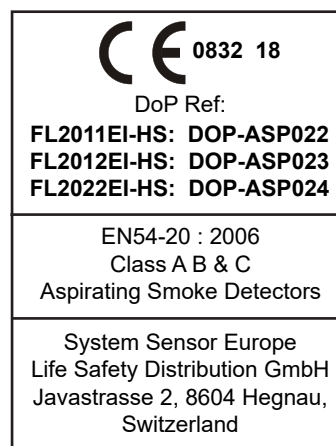

System Sensor Europe
Pittway Tecnologica S.r.l.
Via Caboto 19/3
34147 TRIESTE
Italy

APPENDIX A - PipeIQ™ and PIPE SYSTEM DESIGN

USING PipeIQ™ for SYSTEM DESIGN

PipeIQ is a design application to help a user create EN54 compliant pipe layouts. Generating a suitable working design will require some thought and understanding of the interacting variables in an aspirating system.

The following methodology can assist when trying to design a pipe network using PipeIQ. By following this sequence of steps, it should be possible to arrive at an acceptable design (assuming one exists) that has adequate air flow and hole sensitivity to operate within the overall limits of the aspirating device. (See *Pipe Design Methodology Flow Chart*.)

Suggested Design Methodology

1. Start a project in PipeIQ, choose the detector type, select the aspirating class and follow the instructions to add a detector and create a representation of the physical pipe layout.

To optimise the design:

2. In the **Manage Pipe – Edit Properties** window, set the number of sample holes and hole spacing in the pipe network to comply with local fire regulations and the EN54 approved figures. The hole diameters can also be set in this window, or changed later. To end, click **Update Holes** and then **OK**.
3. In the **Design** tab, click on the **Calculations** button; the *Calculation* window will appear. Set the sample hole diameters and fan speed to get the flow in the detector close to 45l/min.
4. Repeat step (3) above to eliminate any red boxes (out-of-range sensitivity, transport time etc.)
5. Check the flow balance is ≥ 0.5 . Using the auto-balance button will probably create multiple sample hole diameters along the pipe; avoid using this button if a single hole size is required. Be aware that the auto-balance function may also reduce the pipe air flow, ensure this is set back close to 45l/min.
6. Repeat from step (3), adjust hole diameters and fan speed to achieve all the above figures.
7. Next, check that the sample hole sensitivity is practical for the chosen class, i.e. it is not too sensitive. Ideally, to avoid false alarms, hole sensitivity for a class C system should be 1%/m or greater and certainly $>0.5\%/m$.
8. If necessary, change the *Alarm* level to reduce the sample hole sensitivity. The detector sensitivity is set from the *Configuration* tab.
9. Repeat from step (3) to finalise the pipe design and save.

Tips to achieve an adequate design

Maintain the air flow in a FAAST LT-200 unit at, or around, its **optimum setting of 45 l/min**. Increase/decrease hole diameters and fan speed to achieve this.

Fewer holes in a pipe will tend to increase the sample hole sensitivity. Adding extra holes close together may mathematically appear to reduce the hole sensitivity, but in practical terms the system sensitivity will remain high. Change the alarm level to raise or lower the sensitivity of the sample holes.

Changing the hole diameter will affect the hole sensitivity and the hole balance. Smaller holes may improve the balance but will reduce the overall flow. Ensure this remains as close to 45l/min as possible. It is recommended that the flow balance is not less than 0.5 for an acceptable design.

Longer pipes will obviously have longer transport times; they also tend to reduce the air flow, which further extends the transport time. Rather than using one long single pipe, the use of a 'T' tap or two pipes per channel can reduce long pipe runs and reduce the transport time. It also helps with maintaining the air flow speed at the optimal level, since it is equivalent to increasing the pipe diameter to the aspirating device;

Pipe Design Methodology Flow Chart

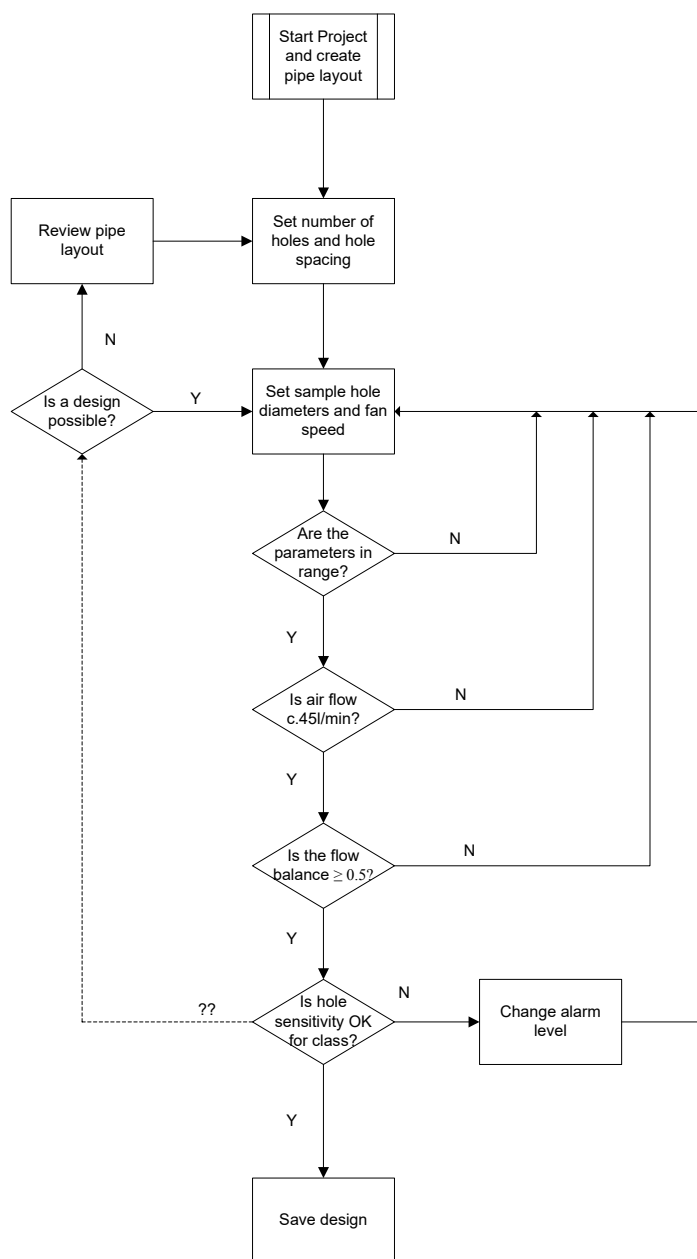

but beware the flow does not get too high. In twin pipe systems it may be necessary to reduce hole sizes, compared with a single pipe, to achieve optimal flow. Alternatively, the fan speed can also be reduced, but both these actions will increase the transport time.

Use of the **Auto-balance** button in PipeIQ will probably give the holes in the pipe design a variety of different diameters. If one size of hole in the sample pipe is desirable (for simpler installation and commissioning) do not use this button. Pipes with equal size sample holes are also easier to test – the farthest end sample hole will be the least sensitive.

APPENDIX B - PRACTICAL PIPE DESIGNS for ASPIRATING SYSTEMS

The following tables show some typical EN54 compliant pipe designs for FAAST LT-200 devices with different overall pipe lengths. Each design has a one size sample hole for ease of installing and testing the system. No exhaust pipe has been included in these designs.

In all the suggested layouts, the sample hole spacing is set to 10m between holes, which is the recommended arrangement for point smoke detectors in the UK (BS 5839). Air flow through the detector has been kept at, or above, 39 l/min for best performance.

In the designs with non-sensing end holes, the distance to the first hole is 9m and the end hole is 1m from the last sample hole.

CLASS C PIPE DESIGNS WITH SINGLE SAMPLE HOLE/END HOLE SIZE AND 10m SPACING 1 PIPE									
Pipe Length	Number of holes	Hole size	End hole*	Air flow	Flow balance	Average sensitivity	Alarm level	Fan	Total hole area
(m)		(mm)	(mm)	(l/min)		(%/m)			(mm ²)
100	10	3	3	40	0.5	0.74	1	10	77.76
90	9	3	3	39	0.53	0.66	1	10	70.70
80	8	3.5	3.5	43	0.52	0.91	2	10	86.60
70	7	3.5	3.5	42	0.62	0.79	2	10	76.98
60	6	4	4	45	0.6	1.14	3	10	87.98
50	5	4.5	4.5	45	0.62	0.98	3	9	95.44
40	4	4.5	4.5	45	0.76	0.80	3	10	79.53
30	3	5	5	46	0.83	1.29	4	10	78.55
20	2	5.5	5.5	45	0.92	0.97	4	10	71.28
10	1	6.5	6.5	45	1	1.31	5	10	66.37

* Non-sensing end hole

CLASS C PIPE DESIGNS WITH SINGLE SAMPLE HOLE/END HOLE SIZE AND 10m SPACING 2 PIPE (T FORM)									
Per pipe length	Number of holes	Hole size	End hole*	Air flow	Flow balance	Average sensitivity	Alarm level	Fan	Total hole area
(m)		(mm)	(mm)	(l/min)		(%/m)			(mm ²)
80	8	2.5	2.5	47	0.71	1.16	1	8	83.46
70	7	2.5	2.5	45	0.77	1.03	1	8	73.64
60	6	3	3	46	0.72	0.91	1	5	91.90
50	5	3	3	45	0.81	1.16	2	6	77.76
40	4	3.5	3.5	45	0.81	0.97	2	4	86.60
30	3	3.5	3.5	44	0.91	1.30	3	6	67.36
20	2	4	4	44	0.95	0.98	3	6	62.84
10	1	5	5	45	1	1.31	4	5	58.91

* Non-sensing end hole

CLASS C PIPE DESIGNS WITH SINGLE SAMPLE HOLE SIZE (Inc. SAMPLING END HOLE) AND 10m SPACING - 1 PIPE									
Pipe Length	Number of holes	Hole size	Air flow	Flow balance	Average sensitivity	Alarm level	Fan	Total hole area	
(m)		(mm)	(l/min)		(%/m)			(mm ²)	
100	X	-	-	-	-	-	-	-	
90	X	-	-	-	-	-	-	-	
80	8	3.5	42	0.6	0.79	2	10	76.98	
70	7	4	44	0.58	0.70	2	10	87.98	
60	6	4.5	44	0.59	1.00	3	9	95.44	
50	5	5.5	45	0.54	0.86	3	8	118.81	
40	4	6	44	0.65	0.67	3	8	113.11	
30	3	6.5	45	0.78	0.99	4	8	99.56	
20	2	6.5	44	0.92	1.31	5	10	66.37	
10	X	-	-	-	-	-	-	-	

X: No adequate or recommended single sample hole size design

CLASS C PIPE DESIGNS WITH SINGLE SAMPLE HOLE SIZE (Inc. SAMPLING END HOLE) AND 10m SPACING - 2 PIPE (T-FORM)								
Pipe Length	Number of holes	Hole size	Air flow	Flow balance	Average sensitivity	Alarm level	Fan	Total hole area
(m)		(mm)	(l/min)		(%/m)			(mm ²)
80	X	-	-	-	-	-	-	-
70	X	-	-	-	-	-	-	-
60	6	3	45	0.8	1.17	2	6	84.83
50	5	3	44	0.87	0.97	2	8	70.70
40	4	3.5	46	0.89	0.79	2	7	76.98
30	3	4	46	0.93	0.98	3	6	75.41
20	2	5	46	0.96	0.66	3	6	78.55
10	1	6.5	44	1	1.31	5	8	66.37

X: No adequate or recommended single sample hole size design

CLASS B PIPE DESIGNS WITH SINGLE SAMPLE HOLE SIZE (Inc. SAMPLING END HOLE) AND 10m SPACING 1 PIPE									
Pipe Length	Number of holes	Hole size	End hole	Air flow	Flow balance	Average sensitivity	Alarm level	Fan	Total hole area
(m)		(mm)	(mm)	(l/min)		(%/m)			(mm ²)
80	X	-	-	-	-	-	-	-	-
70	6	4	4	39	0.68	0.40	1	10	75.41
60	6	4	4	43	0.7	0.39	1	10	75.41
50	5	5.5	5.5	45	0.54	0.34	1	8	118.81
40	4	6	6	46	0.65	0.40	2	8	113.11
30	3	6.5	6.5	45	0.78	0.30	2	8	99.56
20	2	6.5	6.5	44	0.94	0.33	3	10	66.37
10	X	-	-	-	-	-	-	-	-

X: No adequate or recommended single sample hole size design

CLASS B PIPE DESIGNS WITH SINGLE SAMPLE HOLE SIZE (Inc. SAMPLING END HOLE) AND 10m SPACING 2 PIPE (T-FORM)									
Each pipe	Number of holes	Hole size	End hole	Air flow	Flow balance	Average sensitivity	Alarm level	Fan	Total hole area
(m)	(per pipe)	(mm)	(mm)	(l/min)		(%/m)			(mm ²)
50	3	5	5	45	0.84	0.40	1	4	117.83
40	3	4.5	4.5	46	0.89	0.40	1	5	95.44
30	3	4	4	46	0.93	0.40	1	7	75.41
20	2	5	5	46	0.96	0.40	2	6	78.55
10	1	6.5	6.5	44	1	0.33	3	8	66.37

CLASS A PIPE DESIGNS WITH SINGLE SAMPLE HOLE SIZE (Inc. SAMPLING END HOLE) AND 10m SPACING 1 PIPE									
Pipe Length	Number of holes	Hole size	End hole	Air flow	Flow balance	Average sensitivity	Alarm level	Fan	Total hole area
(m)		(mm)	(mm)	(l/min)		(%/m)			(mm ²)
80	X	-	-	-	-	-	-	-	-
70	X	-	-	-	-	-	-	-	-
60	X	-	-	-	-	-	-	-	-
50	X	-	-	-	-	-	-	-	-
40	3	5.5	5.5	40	0.86	0.20	1	10	71.28
30	3	6	6	46	0.83	0.20	1	9	84.83
20	2	6.5	6.5	44	0.94	0.14	1	10	66.37
10	X	-	-	-	-	-	-	-	-

X: No adequate or recommended single sample hole size design

CLASS A PIPE DESIGNS WITH SINGLE SAMPLE HOLE SIZE (Inc. SAMPLING END HOLE) AND 10m SPACING 2 PIPE (T-FORM)									
Each pipe	Number of holes	Hole size	End hole	Air flow	Flow balance	Average sensitivity	Alarm level	Fan	Total hole area
(m)	(per pipe)	(mm)	(mm)	(l/min)		(%/m)			(mm ²)
50	3	5	5	45	0.84	0.40	1	4	117.83
40	3	4.5	4.5	46	0.89	0.40	1	5	95.44
30	3	4	4	46	0.93	0.40	1	7	75.41
20	2	5	5	46	0.96	0.40	2	6	78.55
10	1	6.5	6.5	44	1	0.33	3	8	66.37