



OPERATING INSTRUCTIONS

SPEAKER SYSTEMS

F-1000B

F-1000W

F-1000BT

F-1000WT

F-1000BTWP

F-1000WTWP

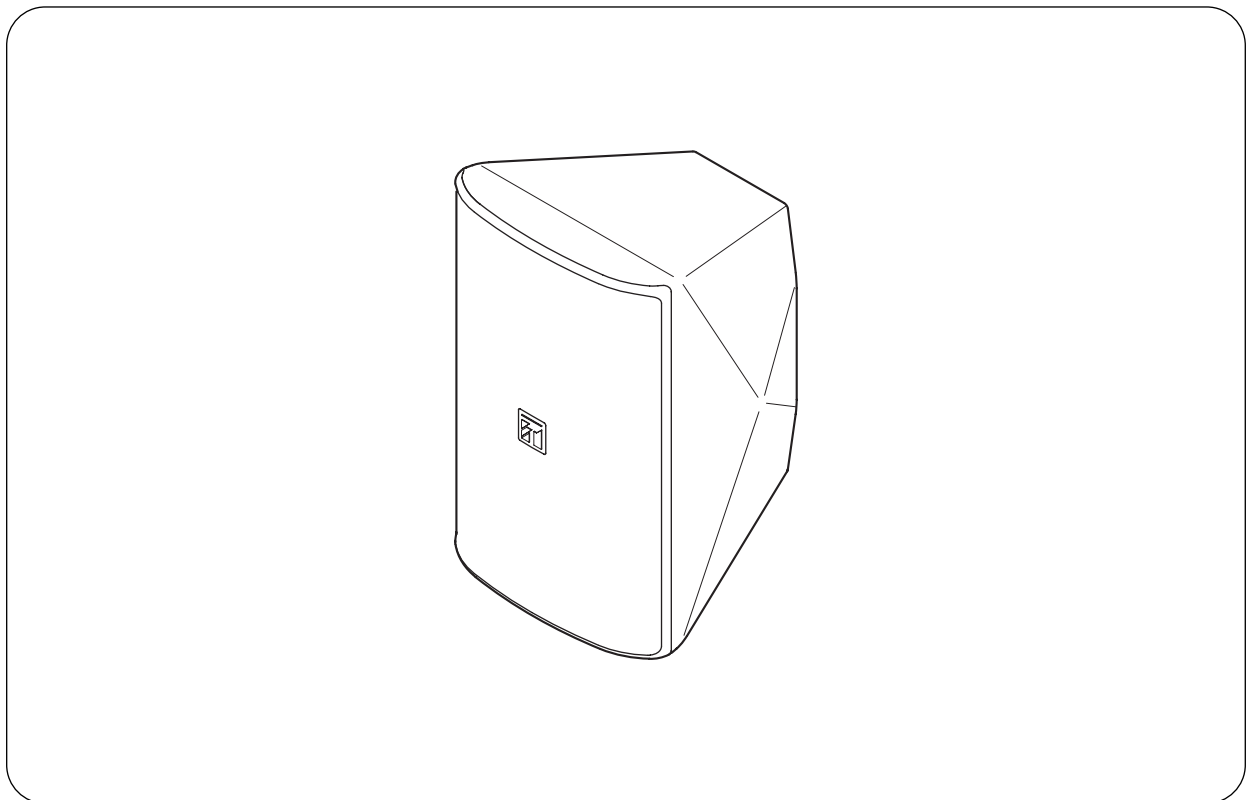

Thank you for purchasing TOA's Speaker System.

Please carefully follow the instructions in this manual to ensure long, trouble-free use of your equipment.

TABLE OF CONTENTS

1. SAFETY PRECAUTIONS	3
2. GENERAL DESCRIPTION	4
3. FEATURES	4
4. DIMENSIONAL DIAGRAM	4
5. IMPEDANCE CHANGE (F-1000BT, F-1000BTWP, F-1000WT, and F-1000WTWP only).....	5
6. ABOUT THE INPUT OVERLOAD PROTECTION CIRCUITRY (F-1000B and F-1000W only)	5
7. NOTES ON OUTDOOR INSTALLATION (F-1000BTWP and F-1000WTWP only)	6
8. INSTALLATION	
8.1. Using the Supplied Brackets	
8.1.1. When using only the supplied brackets	7
8.1.2. When using both the supplied and optional mounting brackets	7
8.2. Speaker Cable Connections	7
8.3. Wall Mounting	8
8.4. Ceiling Mounting	10
8.5. Speaker Stand Mounting	12
8.6. Pole Mounting	13
8.7. Partition Board Mounting (F-1000B, F-1000BT, F-1000W, and F-1000WT only)	14
9. REPAINTING THE SPEAKER	15
10. SPECIFICATIONS	
10.1. F-1000B and F-1000W	16
10.2. F-1000BT and F-1000WT	17
10.3. F-1000BTWP and F-1000WTWP	18

1. SAFETY PRECAUTIONS

- Before installation or use, be sure to carefully read all the instructions in this section for correct and safe operation.
- Be sure to follow all the precautionary instructions in this section, which contain important warnings and/or cautions regarding safety.
- After reading, keep this manual handy for future reference.

Safety Symbol and Message Conventions

Safety symbols and messages described below are used in this manual to prevent bodily injury and property damage which could result from mishandling. Before operating your product, read this manual first and understand the safety symbols and messages so you are thoroughly aware of the potential safety hazards.

WARNING

Indicates a potentially hazardous situation which, if mishandled, could result in death or serious personal injury.

When Installing the Unit

- Install the unit only in a location that can structurally support the weight of the unit and the mounting bracket. Doing otherwise may result in the unit falling down and causing personal injury and/or property damage.
- Do not use other methods than specified to mount the bracket. Extreme force is applied to the unit and the unit could fall off, possibly resulting in personal injuries.
- Use nuts and bolts that are appropriate for the ceiling's or wall's structure and composition. Failure to do so may cause the speaker to fall, resulting in material damage and possible personal injury.
- Tighten each nut and bolt securely. Ensure that the bracket has no loose joints after installation to prevent accidents that could result in personal injury.
- Do not mount the unit in locations exposed to constant vibration. The mounting bracket can be damaged by excessive vibration, potentially causing the unit to fall, which could result in personal injury.
- (F-1000B, F-1000BT, F-1000W, F-1000WT only)
Since the unit is designed for in-door use, do not install it outdoors. If installed outdoors, the aging of parts causes the unit to fall off, resulting in personal injury. Also, when it gets wet with rain, there is a danger of electric shock.
- (F-1000BTWP, F-1000WTWP only)
When installing the unit in the snowy area, take appropriate measures to prevent snow from lying on the unit. If the snow lies on the unit, the unit may fall, causing personal injuries.

- Do not use anti-rust lubricant. If it contacts resin or rubber parts, they could deteriorate and cause the unit to fall, possibly resulting in personal injury.
- Avoid installing the speaker in locations close to the seashore or in indoor swimming facilities that are not well ventilated. In such locations the bracket may be vulnerable to corrosion, eventually allowing the speaker to fall resulting in personal injury.

CAUTION

Indicates a potentially hazardous situation which, if mishandled, could result in moderate or minor personal injury, and/or property damage.

When Installing the Unit

- Avoid touching the unit's sharp metal edge to prevent injury.
- To avoid electric shocks, be sure to switch off the unit's power when connecting speakers.

When the Unit is in Use

- Do not place heavy objects on the unit as this may cause it to fall or break which may result in personal injury and/or property damage. In addition, the object itself may fall off and cause injury and/or damage.
- Do not operate the unit for an extended period of time with the sound distorting. This is an indication of a malfunction, which in turn can cause heat to generate and result in a fire.
- Do not stand or sit on, nor hang down from the unit as this may cause it to fall down or drop, resulting in personal injury and/or property damage.
- Have the unit checked periodically by the shop from where it was purchased. Failure to do so may result in corrosion or damage to the unit or its mounting bracket that could cause the unit to fall, possibly causing personal injury.

2. GENERAL DESCRIPTION

TOA's F-1000 Series Speakers are compact two-way speaker systems designed for high efficiency, wide range, and high power input handling capability. These speaker systems can be installed in a manner ideal for the location and intended application.

3. FEATURES

- 90° horizontal x 90° vertical wide directivity high-frequency horn.
- Supplied bracket permits mounting to a wall, ceiling, or an optional speaker stand.
- Combined use of the supplied bracket and optional mounting bracket allows the speakers to be mounted in many different applications, including pole mounting,*¹ clusters, horizontal ceiling mounting*², and partition board mounting*².
- Both the F-1000BTWP and F-1000WTWP feature a waterproof design (IPX4 standard) for protection from any adverse effects of outdoor installations.

*¹ Applies to the F-1000BTWP and F-1000WTWP.

*² Applies to the F-1000B, F-1000BT, F-1000W, and F-1000WT.

4. DIMENSIONAL DIAGRAM

Unit: mm

[Top]

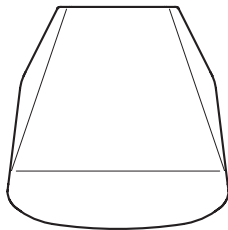

[Bottom]

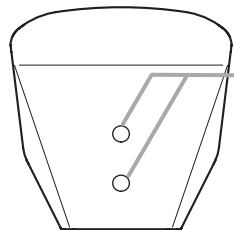

Mounting holes

Note

Hole seals are adhered over the holes at the factory. Before attaching the speaker mounting bracket to this side, remove them using a pointed tool.

[Front]

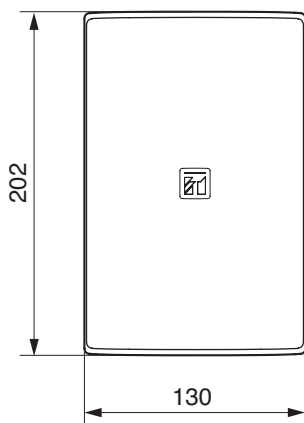

[Side]

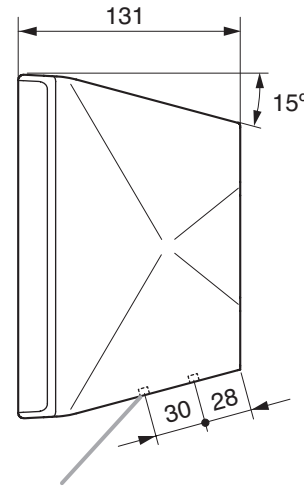

2-M5 mounting screw hole
(Effective screw depth: 14 mm)

[Rear]

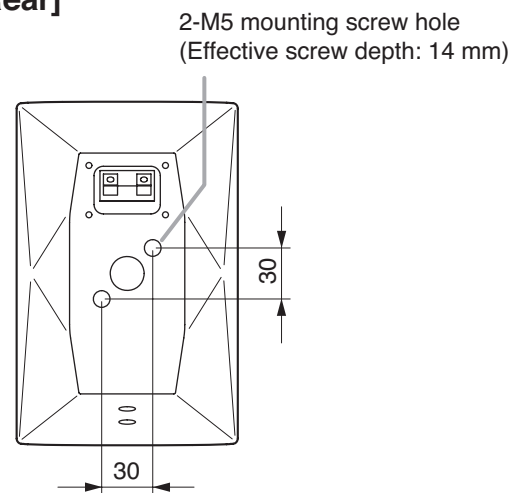

5. IMPEDANCE CHANGE (F-1000BT, F-1000BTWP, F-1000WT, and F-1000WTWP only)

To change the impedance, use a standard screwdriver to rotate the rotary switch on the speaker's rear to select the desired input power.

Note: The switch is factory-preset to 670 Ω .

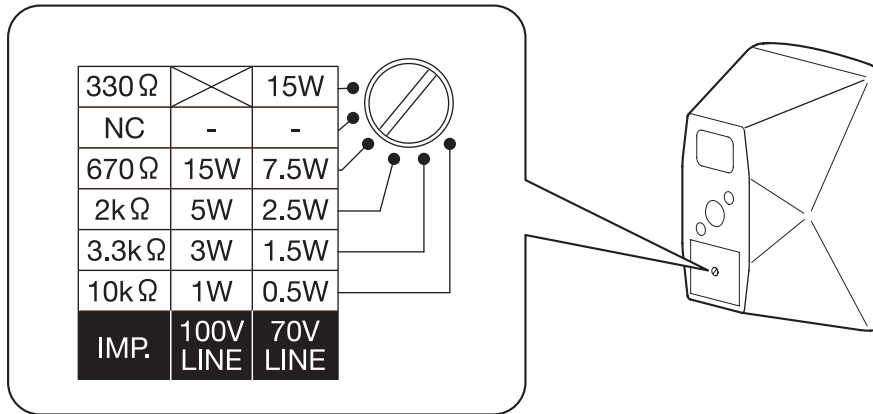

Important

Never set this switch to the "330 Ω " position when operating the speaker on 100 V line. Failure to follow this instruction could result in damage to the speaker or amplifier.

6. ABOUT THE INPUT OVERLOAD PROTECTION CIRCUITRY

(F-1000B and F-1000W only)

The speaker system features internal input overload protection circuitry for both high and low frequencies.

If an excessive input level is fed to the unit, the protection circuitry automatically cuts off the signal to the speaker driver.

A drastic reduction in sound volume for the high or low frequency range indicates that the protection circuitry has been enabled.

In such cases, simply reduce the amplifier volume. The protection circuitry will automatically reset in approximately 10 seconds. After reset, maintain the volume at a level slightly lower than before.

Note

This protection circuitry does not completely protect the unit against input overload. Depending on the type or duration of excessive power input, the protection circuitry might not be enabled, resulting in damage to the speaker driver. Also, if the excessive power input continues for a long period of time, the circuitry may not be capable of resetting to its original condition.

Take care so that the speakers are not exposed to excessive power input.

7. NOTES ON OUTDOOR INSTALLATION (F-1000BTWP and F-1000WTWP only)

- Be sure to mount the speaker in a vertical (portrait-style) orientation.
- Adjust the speaker's tilt angle within the shaded range shown below:

[Wall and pole: 0° horizontal to 45° downward]

[Under eaves: 15° downward to 45° downward]

Note

Mount the speaker so that its rear-mounted terminal cover is positioned on the upper side.

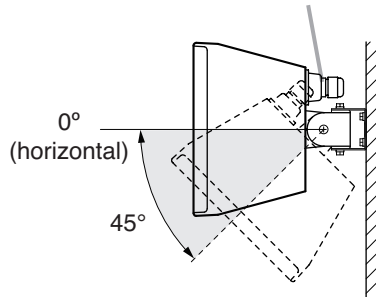

Note

The speaker faces 15° downward when mounting to a horizontal surface.

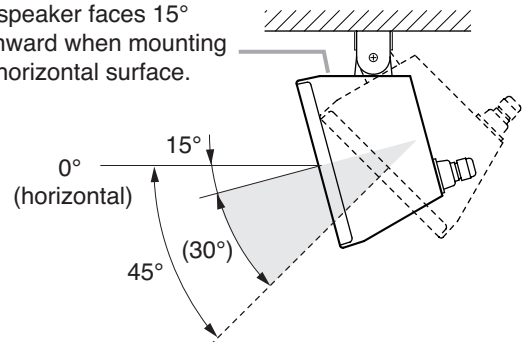

- Install the speaker in locations exposed to an ambient temperature range of -10°C to $+50^{\circ}\text{C}$. Exceeding this range could cause speaker failure.
- Use the supplied terminal cover when connecting the speaker cable.

[Terminal Cover Use]

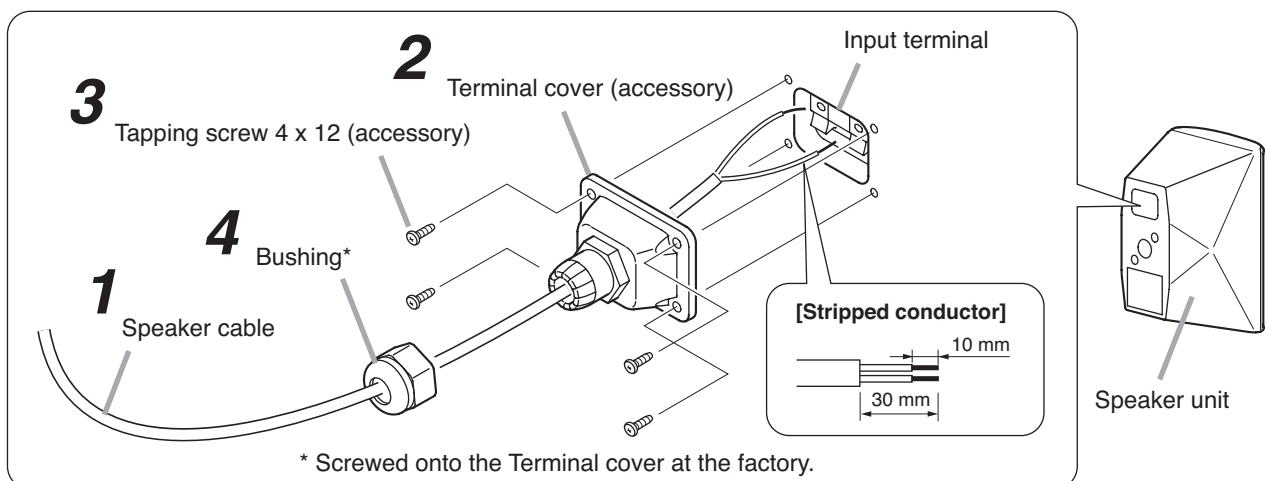

Notes

- For the speaker cable, use a cable with a diameter of 6 – 10 mm, which will fit the cable bushing.
- To ensure waterproof capabilities, firmly mount the terminal cover to the speaker and tighten the bushing on the cover.

Step 1. Feed the speaker cable through the bushing and terminal cover, then connect the cable to the input terminal.

Step 2. Attach the terminal cover to the speaker.
Attach the cover while pulling the cable so that it is not entangled inside the terminal cover.

Step 3. Hold the terminal cover tightly to the speaker using the supplied screws.

Step 4. Tighten the bushing.

Note

After tightening the bushing by hand, use a tool to further tighten it another 90° (1/4-turn) or so. Note that parts can be damaged by over-tightening.

8. INSTALLATION

8.1. Using the Supplied Brackets

The speaker system is supplied with the following brackets. Use these brackets properly depending on the installation location and intended application.

[Speaker bracket]

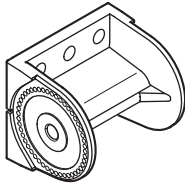

[Joint bracket]

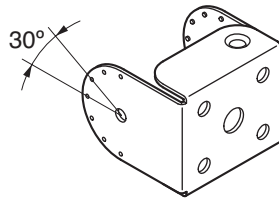

[Wall bracket]

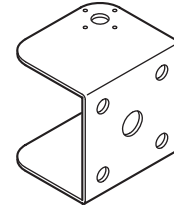

8.1.1. When using only the supplied brackets

Installation Location	Application	Speaker bracket	Joint bracket	Wall bracket	Page
Wall	When horizontal and vertical angle adjustability is desired.	✓	✓	✓	P. 8
	When close wall surface mounting is desired*.	✓	✓	—	P. 9
Ceiling	Vertical speaker mounting*	✓	✓	—	P. 10
Speaker Stand (Option)	Mounting to the optional ST-16A Speaker Stand	✓	✓	—	P. 12

* Speaker coverage angles can only be adjusted in the vertical direction.

8.1.2. When using both the supplied and optional mounting brackets

Installation Location	Application	Option	Speaker bracket	Joint bracket	Wall bracket	Page
Ceiling	Horizontal speaker mounting	HY-CM10B or HY-CM20W	✓	✓	—	P. 11
	Suspended speaker cluster mounting*	HY-CL10B	✓	✓	—	P. 11
Pole	Mounting to a pole	YS-60B	✓	✓	✓	P. 13
Partition board	Mounting to a partition board	HY-BH10B	✓	✓	—	P. 14

* Speaker coverage angles can only be adjusted in the vertical direction.

8.2. Speaker Cable Connections

[Input terminal polarity]

Speaker unit (rear)

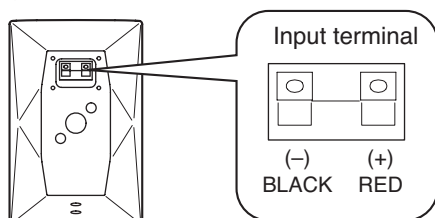

[Stripped conductor of cable]



8.3. Wall Mounting

When adjusting horizontal and vertical angles:

Use the supplied wall bracket, joint bracket, and speaker bracket to permit adjustment of the horizontal and vertical* speaker coverage angles.

- * Vertical installation. Horizontal: Max. 82°, Vertical: Max. 45° downward
- Horizontal installation. Horizontal: Max. 60°, Vertical: Max. 45° downward

[Wall bracket mounting dimensions]

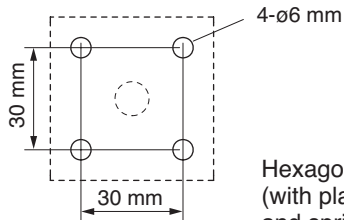

2

Hexagon bolt M6 x 12
(with plain washer
and spring washer)

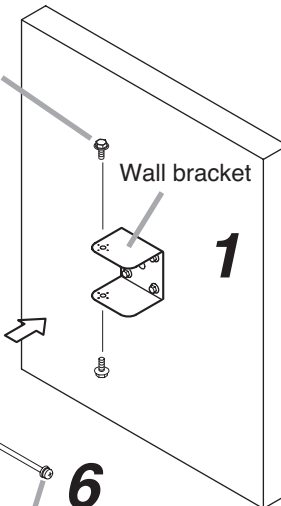

[Installation example]

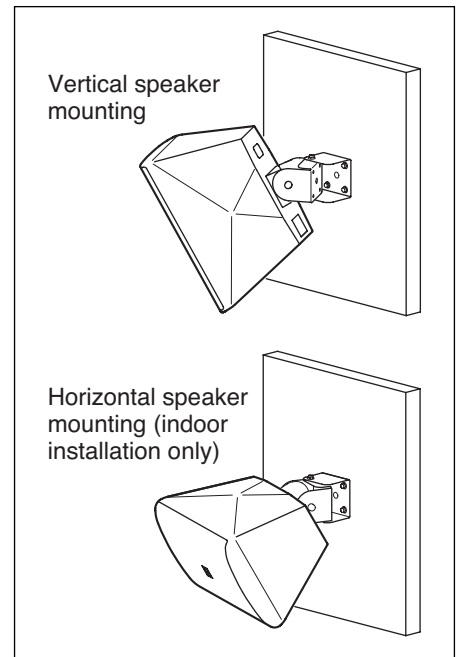

Joint bracket

4

Fixing bolt M5 x 60

6

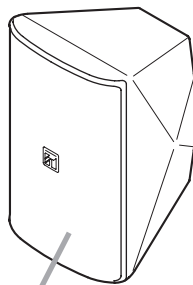

Speaker unit

3

[Vertical speaker installation]

[Horizontal speaker installation]

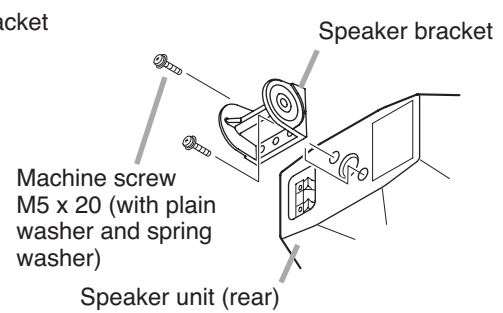
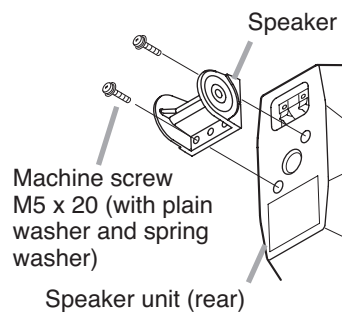

Step 1. Mount the wall bracket to the wall surface.
Match the orientation of the arrow label with the horizontal direction (left or right) the speaker faces.

Note: Hardware used for mounting the wall bracket to the wall is not supplied.

• **Arrow label orientation (Viewed from top of brackets)**

[Left-facing orientation]

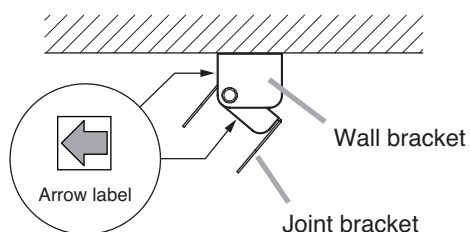

[Right-facing orientation]

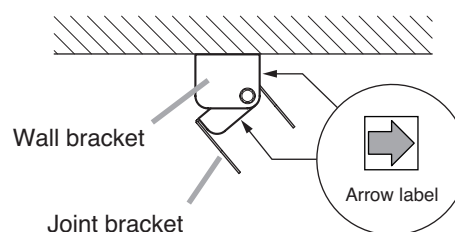

Step 2. Attach the joint bracket to the wall bracket using the supplied screws, adjust the horizontal speaker angle, then tighten the screws.

Note: Match the orientation of the arrows on both the wall bracket and joint bracket.

Step 3. Attach the speaker bracket to the speaker's rear using the supplied screws.

Note: Attach the speaker bracket according to the speaker mounting orientation.

Step 4. Mount the speaker to the joint bracket by inserting the speaker bracket into the joint bracket and loosely securing the fixing bolt for temporary speaker installation.

Step 5. Connect the speaker cable to the input terminal.

Note

Use a terminal cover when installing the speaker outdoors. (Refer to p.6 for terminal cover attachment.)

Step 6. Adjust the speaker's vertical mounting angle and tighten the fixing bolt.

The speaker angle is adjustable in 7.5° steps.

Note

The mating surfaces of the speaker bracket and joint bracket are designed to interlock. Ensure that both parts are securely engaged with each other after mounting is complete.

[Changing the orientation of the front panel logo]

The front panel logo is affixed to the mesh net using double-faced tape. Peel off the logo carefully and reaffix it in the proper orientation.

Mounting the speaker close to a wall surface

Use both the supplied joint bracket and speaker bracket, and mount the joint bracket directly to a wall. After mounting the joint bracket, follow the Steps 3 – 6 above. In this configuration, the speaker can only be adjusted in the vertical direction*.

* Vertical installation: Max. 37.5° downward, Horizontal installation: Max. 45° downward

Note: Hardware used for mounting the joint bracket to the wall is not supplied.

[Joint bracket mounting dimensions]

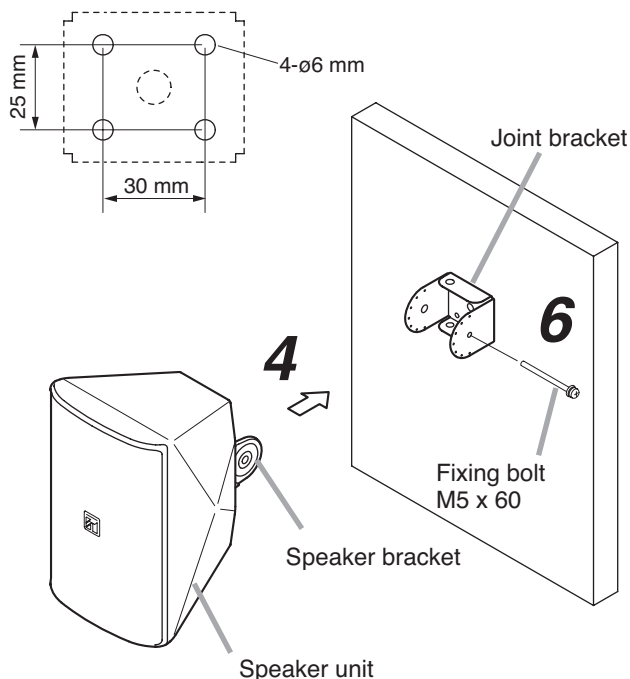

[Installation example]

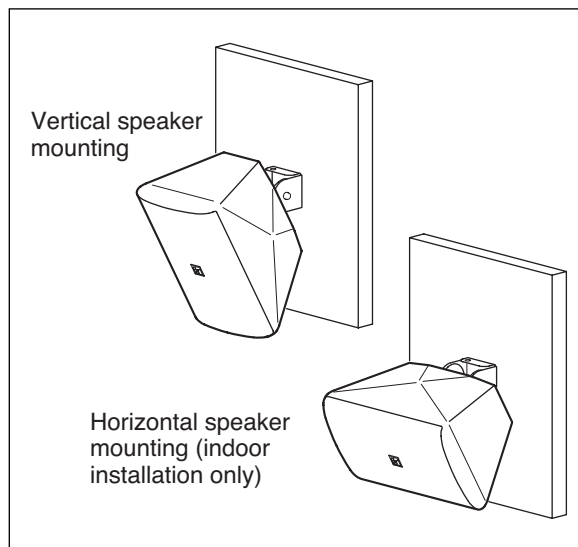

8.4. Ceiling Mounting

Vertical orientation

Use the supplied joint bracket and speaker bracket.

Note

Speaker coverage angles can only be adjusted in the vertical direction (Max. 45° downward). Adjust the speaker's tilt angle within the shaded range shown below:

[Speaker angle vs. Bracket position]

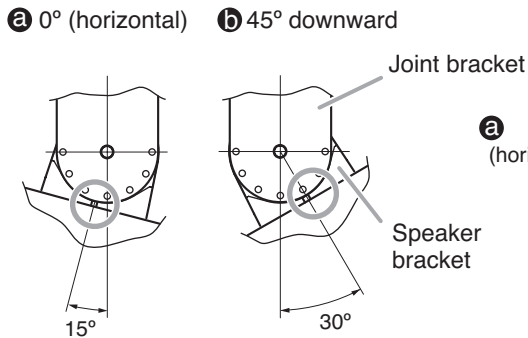

[Installation example]

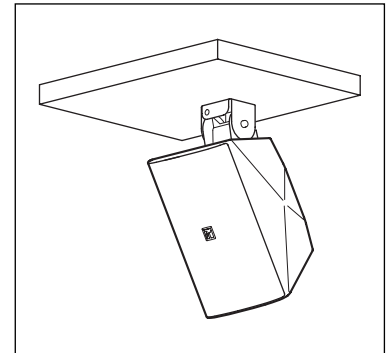

Notes

- Use an appropriate anchor bolt for supporting the full weight of the speaker and for the size of mounting hole in the joint bracket.
- Ensure that the effective length of the anchor bolt is 20 mm or less.
- When speaker rotation capability is not desired, secure with the 4 fixed mounting screw holes.

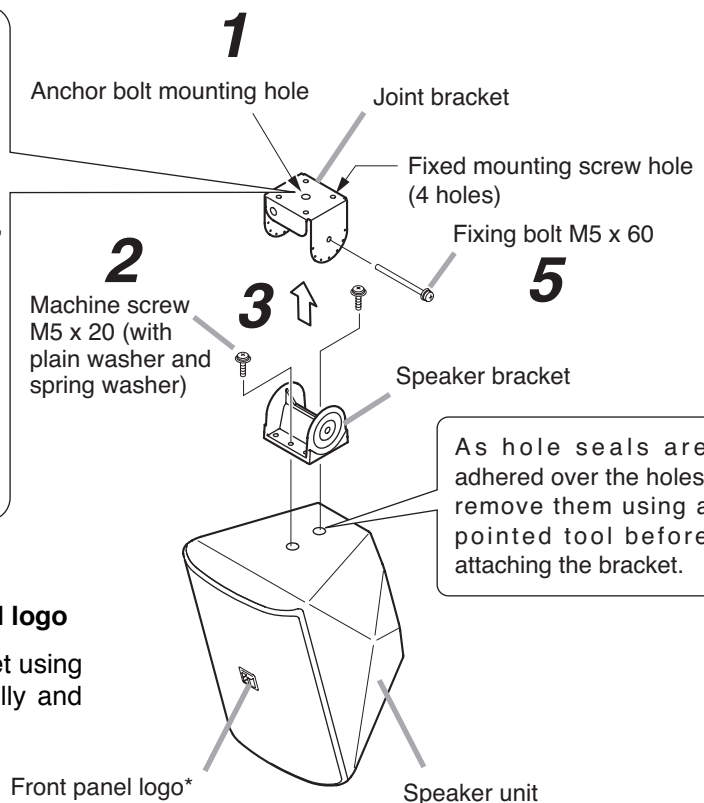
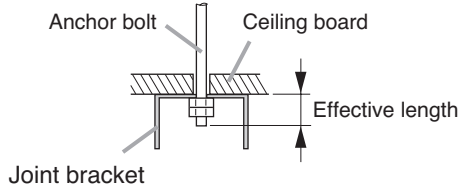

* Changing the orientation of the front panel logo

The front panel logo is affixed to the mesh net using double-faced tape. Peel off the logo carefully and reaffix it in the proper orientation.

Step 1. Mount the joint bracket to the ceiling surface.

Note

Hardware used for mounting the joint bracket to the ceiling is not supplied.

Step 2. Attach the speaker bracket to the speaker's bottom using the supplied screws.

[Joint bracket mounting dimensions]

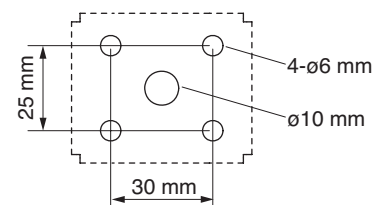

Step 3. Mount the speaker to the joint bracket by inserting the speaker bracket into the joint bracket and loosely securing the fixing bolt for temporary speaker installation.

Step 4. Connect the speaker cable to the input terminal.

Note

Use a terminal cover when installing the speaker outdoors. (Refer to p. 6 for terminal cover attachment.)

Step 5. Adjust the speaker's vertical mounting angle and tighten the fixing bolt.
The speaker angle is adjustable in 7.5° steps.

Note

The mating surfaces of the speaker bracket and joint bracket are designed to interlock. Ensure that both parts are securely engaged with each other after mounting is complete.

Horizontal orientation (F-1000B, F-1000BT, F-1000W, and F-1000WT only)

Use the supplied joint bracket and speaker bracket in combination with the optional HY-CM10B or HY-CM10W Ceiling Mount Bracket. Refer to the instruction manual enclosed with the optional mounting bracket for its mounting details.

[Installation example]

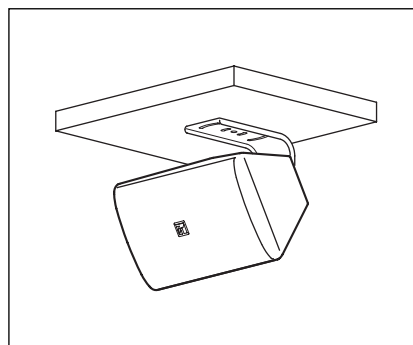

Cluster configuration assembly (F-1000B, F-1000BT, F-1000W, and F-1000WT only)

Use the supplied joint brackets and speaker brackets in combination with the optional HY-CL10B Cluster Bracket to permit a total of 4 speakers to be suspended from the ceiling as shown in the figure at right. Refer to the instruction manual enclosed with the optional mounting bracket for its mounting details.

[Installation example]

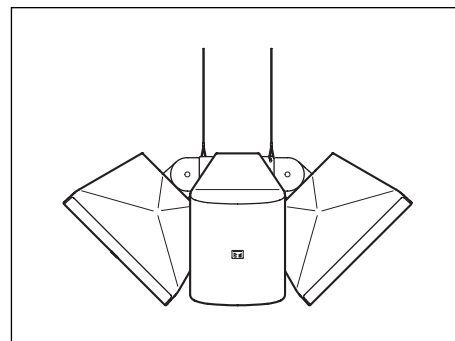

8.5. Speaker Stand Mounting

The speaker can be mounted on the optional ST-16A Speaker Stand using the supplied joint bracket and speaker bracket.

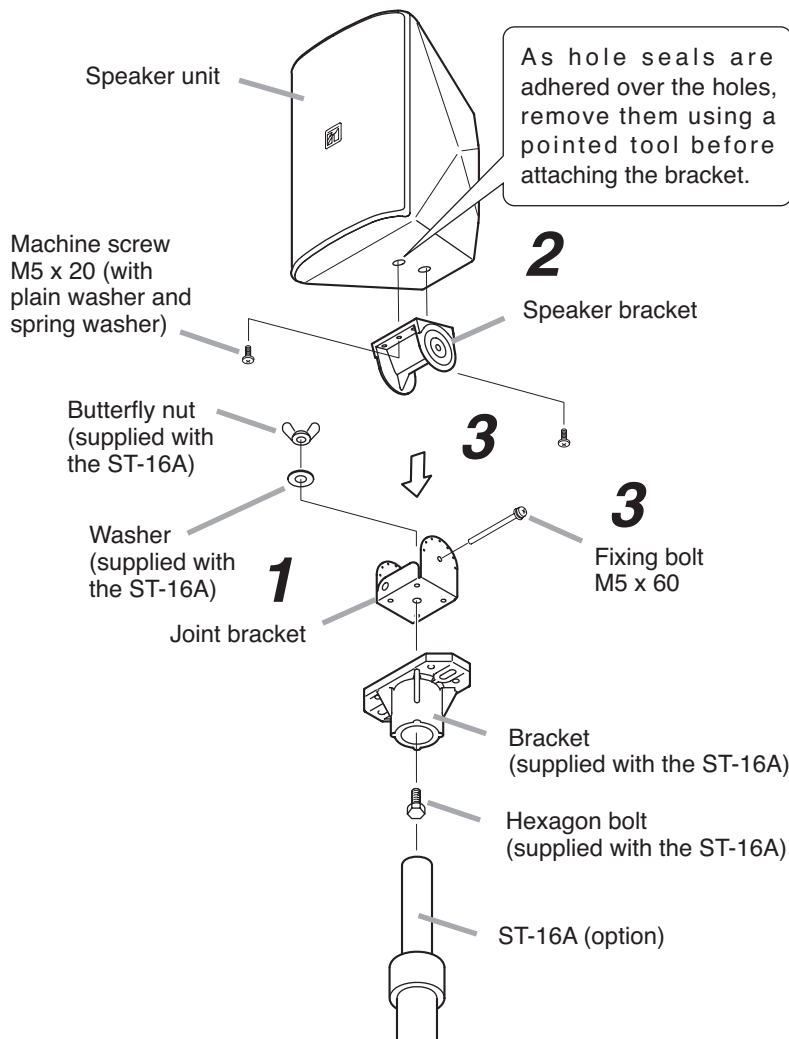

[Installation example]

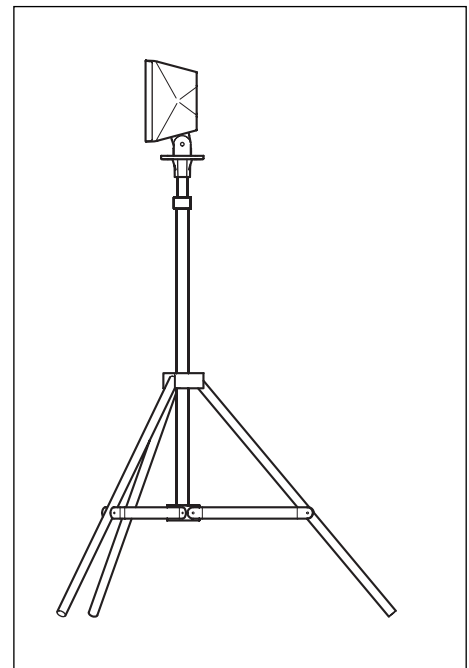

Note

Mount the speaker so that it faces within the range of 15° upward and downward.

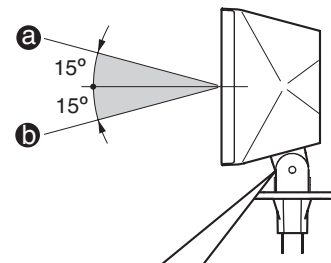

Step 1. Attach the joint bracket to the speaker stand bracket using the speaker stand's supplied bolt and nut.

Step 2. Attach the speaker bracket to the speaker's bottom using the supplied screws.

Step 3. Mount the speaker to the joint bracket by inserting the speaker bracket into the joint bracket and loosely securing the fixing bolt for temporary speaker installation. After adjusting the speaker's vertical mounting angle, tighten the fixing bolt. The speaker angle is adjustable in 7.5° steps.

The mating surfaces of the speaker bracket and joint bracket are designed to interlock. Ensure that both parts are securely engaged with each other after mounting is complete.

Step 4. Connect the speaker cable to the input terminals.

Note

Use a terminal cover when installing the speaker outdoors. (Refer to p. 6 for terminal cover attachment.)

Note

For more information on mounting the bracket to the stand and stand usage, refer to the instruction manual enclosed with the ST-16A Speaker Stand.

[Speaker angle vs. Bracket position]

a 15° upward **b** 15° downward

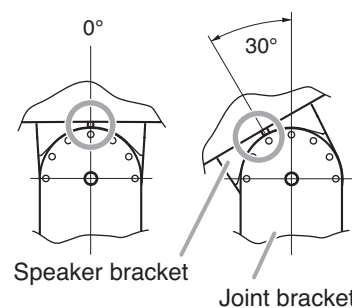

8.6. Pole Mounting (F-1000BTWP and F-1000WTWP only)

To mount the speaker on a pole with diameter of 10 – 34 cm, use the supplied wall bracket, joint bracket, and speaker bracket in combination with the optional YS-60B Pole Band.

Speaker coverage angles can be adjusted in the horizontal and vertical direction*.

* Horizontal: Max. 90°, Vertical: Max. 45° downward

[Installation example]

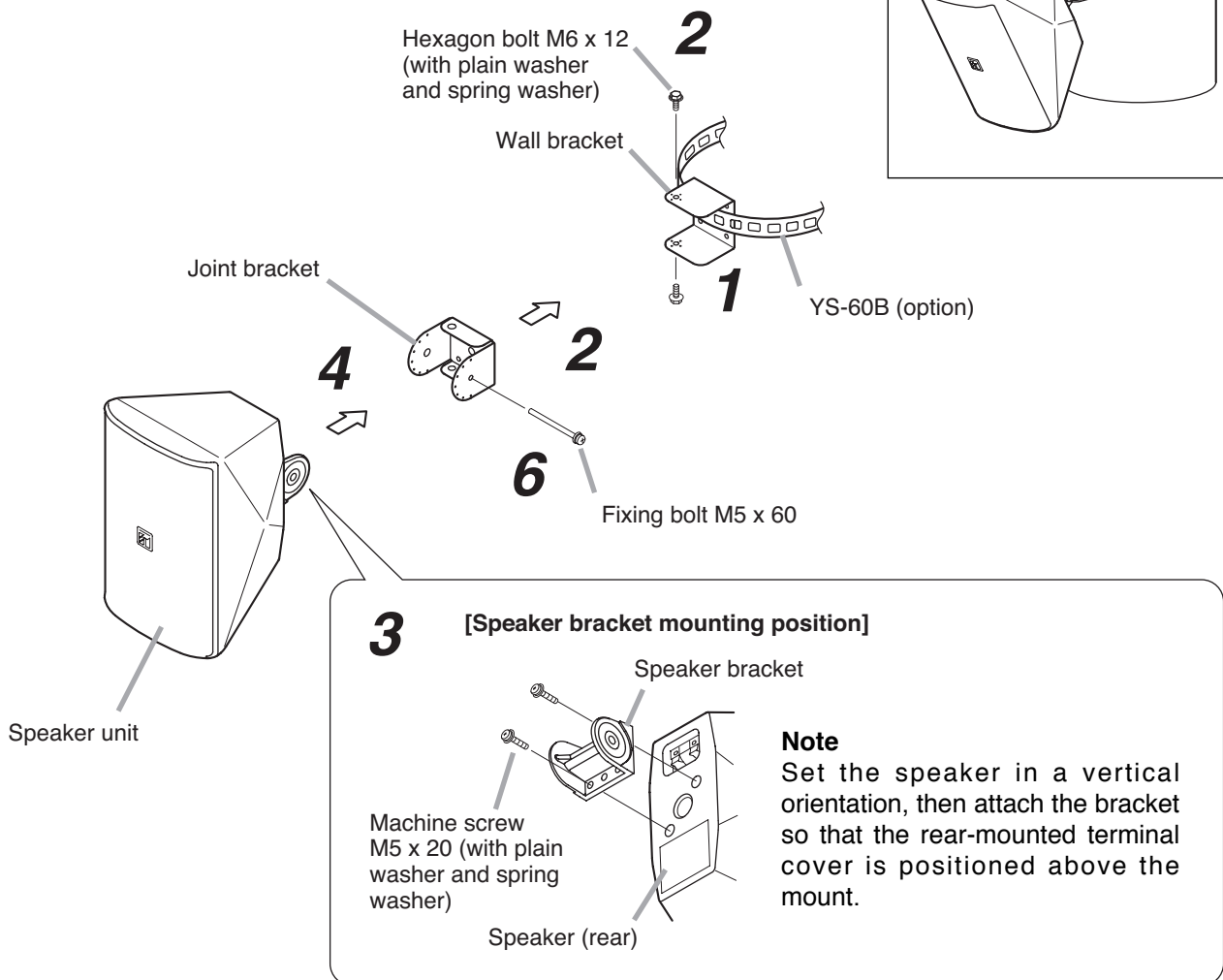
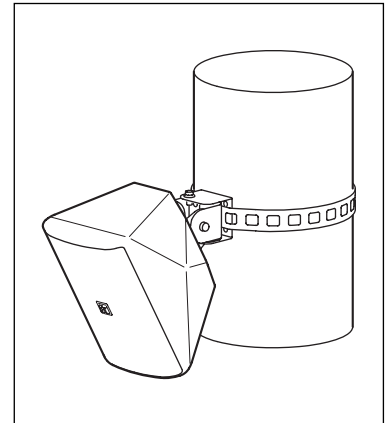

Step 1. Attach the wall bracket to a pole using the YS-60B.

• **Arrow label orientation (Viewed from top of brackets)**

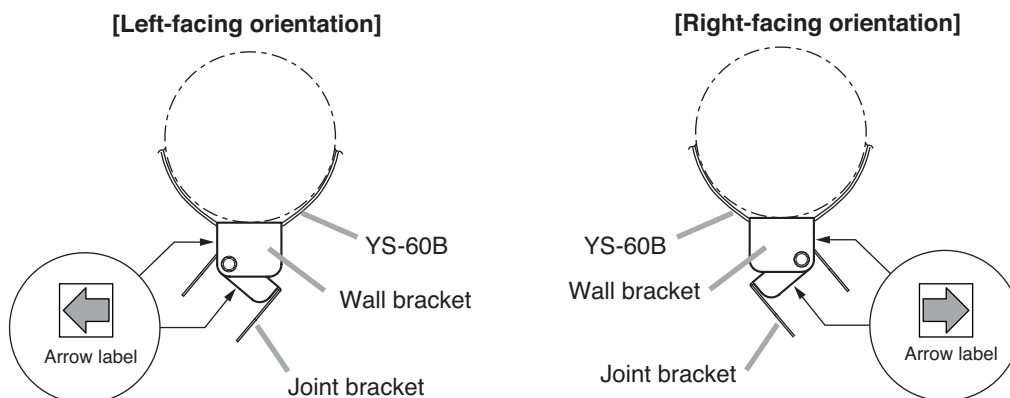

Step 2. Attach the joint bracket to the wall bracket using the supplied screws, adjust the horizontal speaker angle, then tighten the screws.

Note

Match the orientation of the arrows on both the wall bracket and joint bracket.

Step 3. Attach the speaker bracket to the speaker's rear using the supplied screws.

Note

Set the speaker in a vertical orientation, then attach the bracket so that the rear-mounted terminal cover is positioned above the mount.

Step 4. Mount the speaker to the joint bracket by inserting the speaker bracket into the joint bracket and loosely securing the fixing bolt for temporary speaker installation.

Step 5. Connect the speaker cable to the input terminal.

Note

Use a terminal cover when installing the speaker outdoors. (Refer to p. 6 for terminal cover attachment.)

Step 6. Adjust the speaker's vertical mounting angle and tighten the fixing bolt. The speaker angle is adjustable in 7.5° steps.

Note

The mating surfaces of the speaker bracket and joint bracket are designed to interlock. Ensure that both parts are securely engaged with each other after mounting is complete.

8.7. Partition Board Mounting (F-1000B, F-1000BT, F-1000W, and F-1000WT only)

Use the supplied joint bracket and speaker bracket in combination with the optional HY-BH10B Board Hanger Bracket. Refer to the instruction manual enclosed with the optional mounting bracket for its mounting details.

[Installation example]

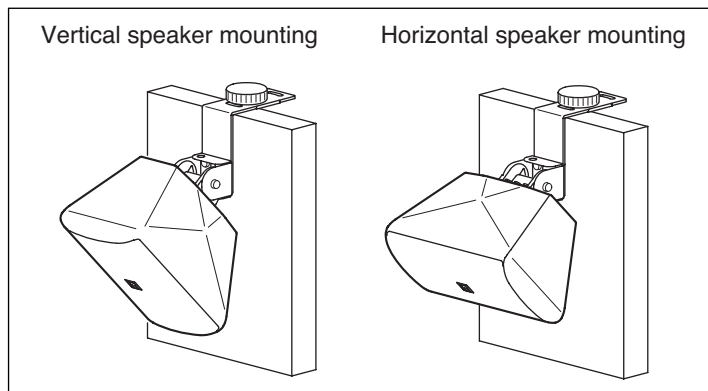

9. REPAINTING THE SPEAKER

Follow the procedure below when repainting the speaker grill and cabinet.

Note

Take care not to touch the speaker diaphragm during work.

Step 1. Peel off the logo carefully, then remove the screw underneath to detach the mesh speaker grill.

[Detaching the mesh grill]

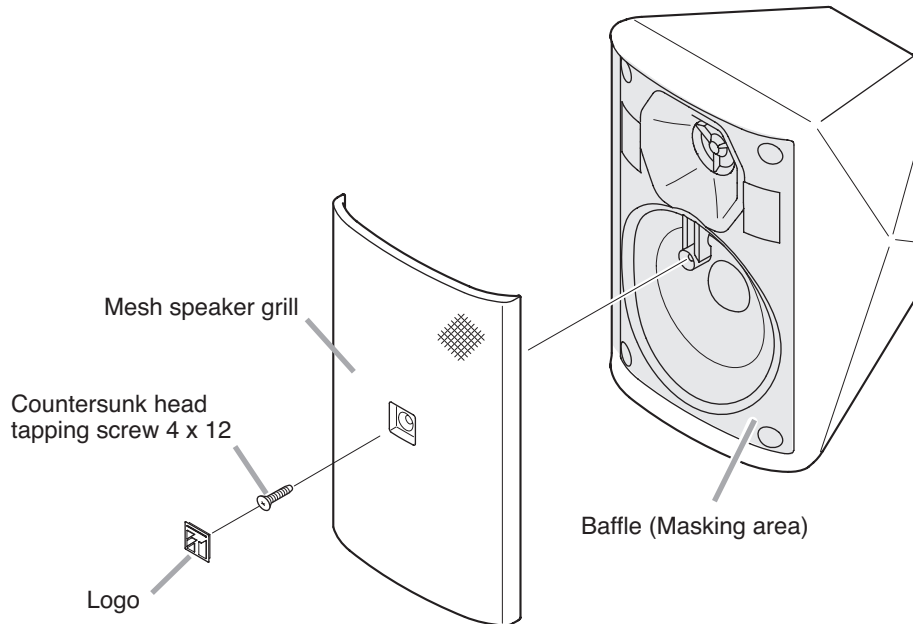

Note

Because the logo is affixed using double-faced tape, peel it off carefully.

Step 2. Wipe clean the mesh grill and speaker cabinet with a soft cloth dampened in a detergent.

Note

Do not use thinner or other volatile liquids to clean the grill and cabinet.

Step 3. Use spray paint to apply thin coat evenly overall the speaker.

Notes

- Avoid painting with a roller or brush, as the grill holes could become clogged with paint.
- Securely mask the entire baffle surface before painting.
- Use appropriate paints for the speaker grill and cabinet materials.
 - Grill: Rolled steel plate (acrylic paint)
 - Cabinet: Fire-resistant HIPS resin

Step 4. After the paint has dried, apply another light coat.

Note

Repeating Step 3, apply 2 or more light coats of paint.

Application of one thick coat of paint all at once may cause drips or unevenness to show up in the painted finish, or clog the mesh holes.

Step 5. After the paint has dried, replace the mesh grill and logo.

10. SPECIFICATIONS

10.1. F-1000B and F-1000W

Model No.	F-1000B	F-1000W
Enclosure Type	Bass-reflex type	
Power Handling Capacity	30 W (continuous pink noise) 90 W (continuous program)	
Rated Impedance	8 Ω	
Output Sound Pressure Level	87 dB (1 W, 1 m) at installation in a semianechoic field	
Frequency Response	85 – 20,000 Hz, –10 dB at installation in a semianechoic field	
Crossover Frequency	5 kHz	
Directivity Angle	Horizontal: 90°, Vertical: 90°	
Speakers	Woofer: 10 cm cone-type Tweeter: balanced dome-type	
Input Terminals	Push-in terminals	
Enclosure	HIPS, black	HIPS, white
Mesh Speaker Grill	Surface-treated steel plate, black, paint	Surface-treated steel plate, white, paint
Speaker Bracket	Aluminum die-cast, black, paint	Aluminum die-cast, white, paint
Joint Bracket, Wall Bracket	Steel plate, t1.6, black, paint	Steel plate, t1.6, white, paint
Dimensions	130 (w) x 202 (h) x 131 (d) mm	
Weight	1.8 kg (including the supplied brackets)	
Accessories	Speaker bracket ... 1, Joint bracket ... 1, Wall bracket ... 1, Fixing bolt M5 x 60 ... 1, Hexagon bolt M6 x 12 (with plain washer and spring washer) ... 2, Machine screw M5 x 20 (with plain washer and spring washer) ... 2	
Optional Products	Board hanger bracket: HY-BH10B Ceiling mount bracket: HY-CM10B Cluster bracket: HY-CL10B Speaker stand: ST-16A	Board hanger bracket: HY-BH10B Ceiling mount bracket: HY-CM10W Cluster bracket: HY-CL10B Speaker stand: ST-16A

Note: The design and specifications are subject to change without notice for improvement.

10.2. F-1000BT and F-1000WT

Model No.	F-1000BT	F-1000WT
Enclosure Type	Bass-reflex type	
Power Handling Capacity	15 W	
Rated Impedance	670 Ω (15 W), 2 k Ω (5 W), 3.3 k Ω (3 W), 10 k Ω (1 W)	
Output Sound Pressure Level	87 dB (1 W, 1 m) at installation in a semianechoic field	
Frequency Response	85 – 20,000 Hz, –10 dB at installation in a semianechoic field	
Crossover Frequency	5 kHz	
Directivity Angle	Horizontal: 90°, Vertical: 90°	
Speakers	Woofer: 10 cm cone-type Tweeter: balanced dome-type	
Input Terminals	Push-in terminals	
Enclosure	HIPS, black	HIPS, white
Mesh Speaker Grill	Surface-treated steel plate, black, paint	Surface-treated steel plate, white, paint
Speaker Bracket	Aluminum die-cast, black, paint	Aluminum die-cast, white, paint
Joint Bracket, Wall Bracket	Steel plate, t1.6, black, paint	Steel plate, t1.6, white, paint
Dimensions	130 (w) x 202 (h) x 131 (d) mm	
Weight	2 kg (including the supplied brackets)	
Accessories	Speaker bracket ... 1, Joint bracket ... 1, Wall bracket ... 1, Fixing bolt M5 x 60 ... 1, Hexagon bolt M6 x 12 (with plain washer and spring washer) ... 2, Machine screw M5 x 20 (with plain washer and spring washer) ... 2	
Optional Products	Board hanger bracket: HY-BH10B Ceiling mount bracket: HY-CM10B Cluster bracket: HY-CL10B Speaker stand: ST-16A	Board hanger bracket: HY-BH10B Ceiling mount bracket: HY-CM10W Cluster bracket: HY-CL10B Speaker stand: ST-16A

Note: The design and specifications are subject to change without notice for improvement.

10.3. F-1000BTWP and F-1000WTWP

Model No.	F-1000BTWP	F-1000WTWP
Enclosure Type	Bass-reflex type	
Power Handling Capacity	15 W	
Rated Impedance	670 Ω (15 W), 2 k Ω (5 W), 3.3 k Ω (3 W), 10 k Ω (1 W)	
Output Sound Pressure Level	87 dB (1 W, 1 m) at installation in a semianechoic field	
Frequency Response	85 – 20,000 Hz, –10 dB at installation in a semianechoic field	
Crossover Frequency	5 kHz	
Directivity Angle	Horizontal: 90°, Vertical: 90°	
Speakers	Woofer: 10 cm cone-type Tweeter: balanced dome-type	
Input Terminals	Push-in terminals	
Water Resistance	IPX4	
Operating Temperature	–10 °C to +50 °C	
Enclosure	HIPS, black	HIPS, white
Mesh Speaker Grill	Surface-treated steel plate, black, anti-rust paint	Surface-treated steel plate, white, anti-rust paint
Speaker Bracket	Aluminum die-cast, black, paint	Aluminum die-cast, white, paint
Joint Bracket, Wall Bracket	Stainless steel (SUS 304), t1.5	
Dimensions	130 (w) x 202 (h) x 131 (d) mm	
Weight	2 kg (including the supplied brackets)	
Accessories	Speaker bracket ... 1, Joint bracket ... 1, Wall bracket ... 1, Fixing bolt M5 x 60 ... 1, Hexagon bolt M6 x 12 (with plain washer and spring washer) ... 2, Machine screw M5 x 20 (with plain washer and spring washer) ... 2, Terminal cover ... 1, Tapping screw 4 x 12 ... 4	
Optional Products	Pole band: YS-60B	

Note: The design and specifications are subject to change without notice for improvement.